

PNP Transistor for extra current from 15V regulator

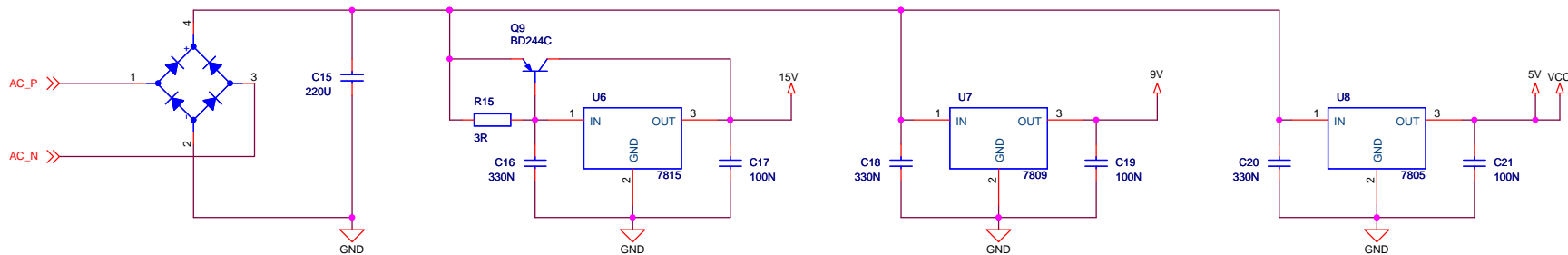

<Schematic Path>
Schematic

| | | | |
|--|--|---|--|
| Schematic Title | | TeslaCom 2009 | |
| Page Title | | Driver Logic & Power Supply | |
| Designed: <OrgAddr1> | | Approved: <OrgAddr2> | |
| Size A3 | | BOM Doc No: <Cage Code> | |
| Design Created Date: Sunday, July 12, 2009 | | Sheet Created Date: Monday, August 24, 2009 | |
| Document number <Doc> | | Revision <RevCode> | |
| Sheet Modified Date: Monday, August 24, 2009 | | Sheet 1 of 2 | |

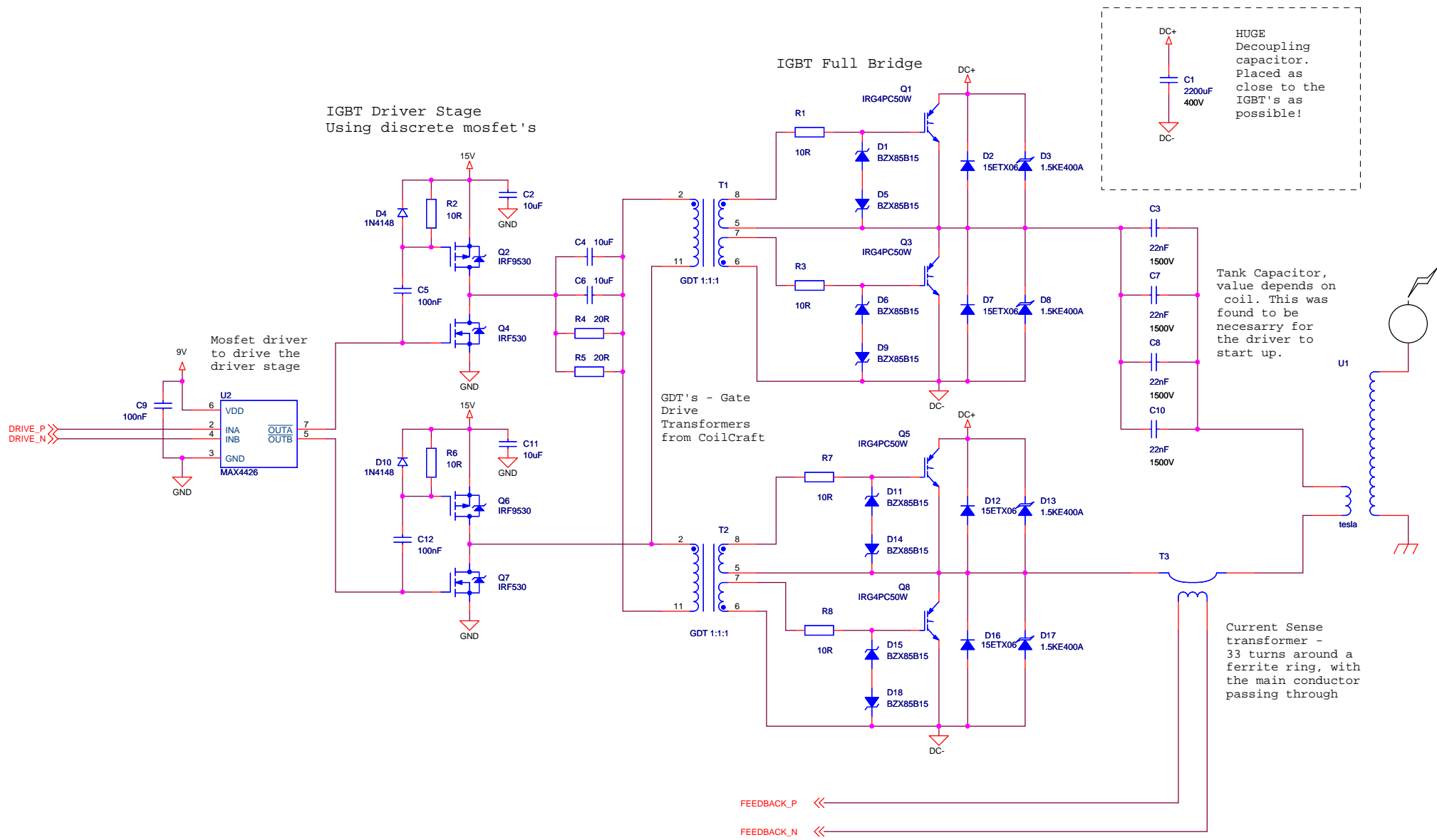

<Schematic Path>
Schematic

| | | | |
|-----------------------|-------------|-----------------------|-------------------------|
| Schematic Title | | TeslaCom 2009 | |
| Page Title | | Power Stage | |
| Designed: | | Approved: | |
| <OrgAddr1> | | <OrgAddr2> | |
| Size | BOM Doc No: | Document number | Revision |
| A3 | <Cage Code> | <Doc> | <RevCode> |
| Design Created Date: | | Sheet Created Date | Sheet Modified Date |
| Sunday, July 12, 2009 | | Sunday, July 12, 2009 | Monday, August 24, 2009 |
| | | Sheet | 1 of 1 |