3 Service

This section provides an overview of the major assemblies and subassemblies that compose the robotic system and gives instructions for parts replacement. Before performing a repair procedure, please read the instructions completely.

Major Assembly Overview

The major assemblies that make up the robotic arm are shown in figure 3-1. Tables keyed to some of the figures provide descriptions and replacement part numbers of major components.

NOTE! Use Loctite 242 (Part no. 0470-0231) thread locking compound when replacing any screws while servicing the robot.

CAUTION

All procedures should be performed with the controller turned off and unplugged. Proper precautions should be taken to protect electronics from damage caused by static discharge.

WARNING

Failure to calibrate the robot after servicing will cause unexpected results that can lead to possible serious physical injury and/or damage to the robot, equipment, and other items located in the work cell.

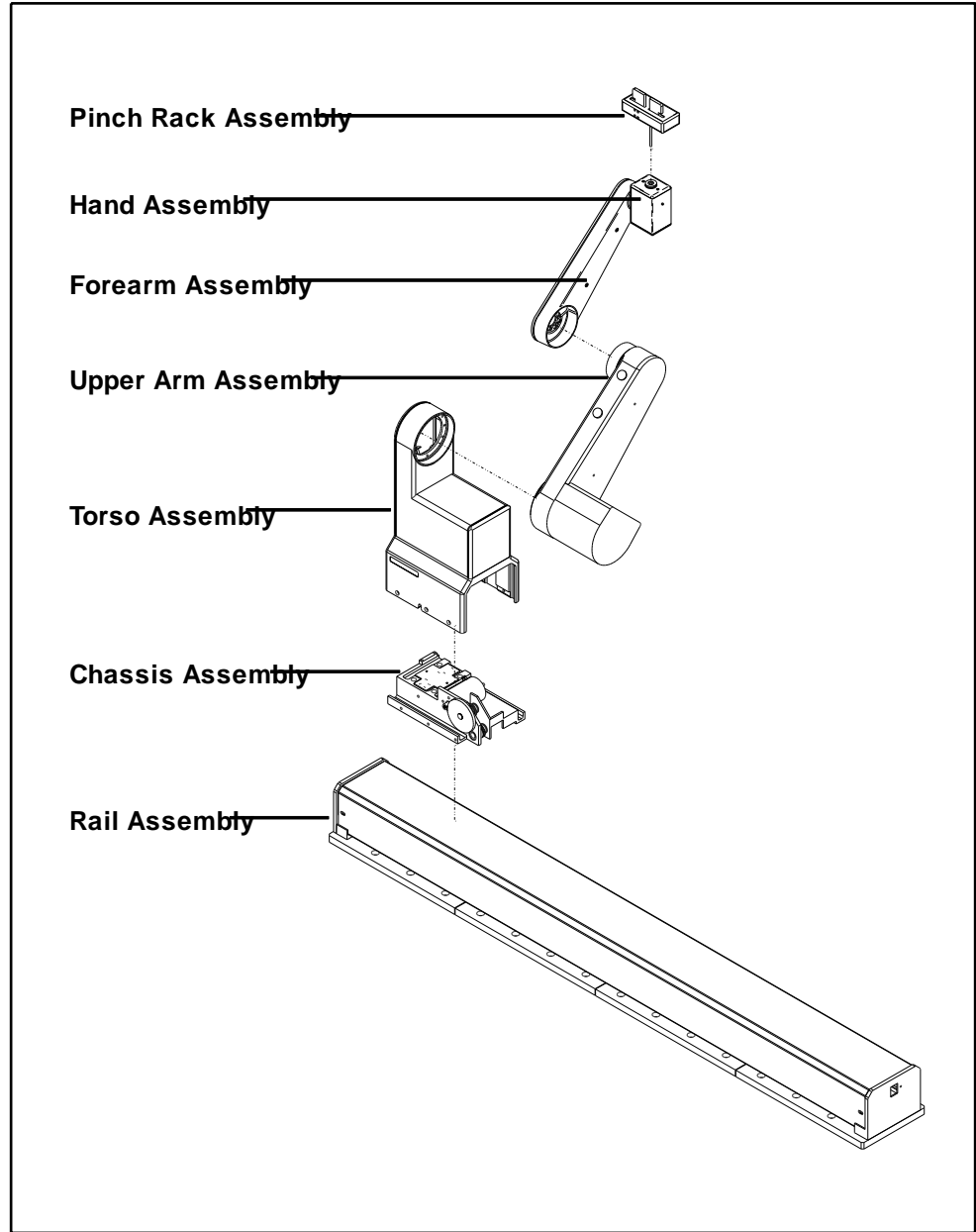

Figure 3-1. Robot arm major assemblies

Pinch Rack and Hand

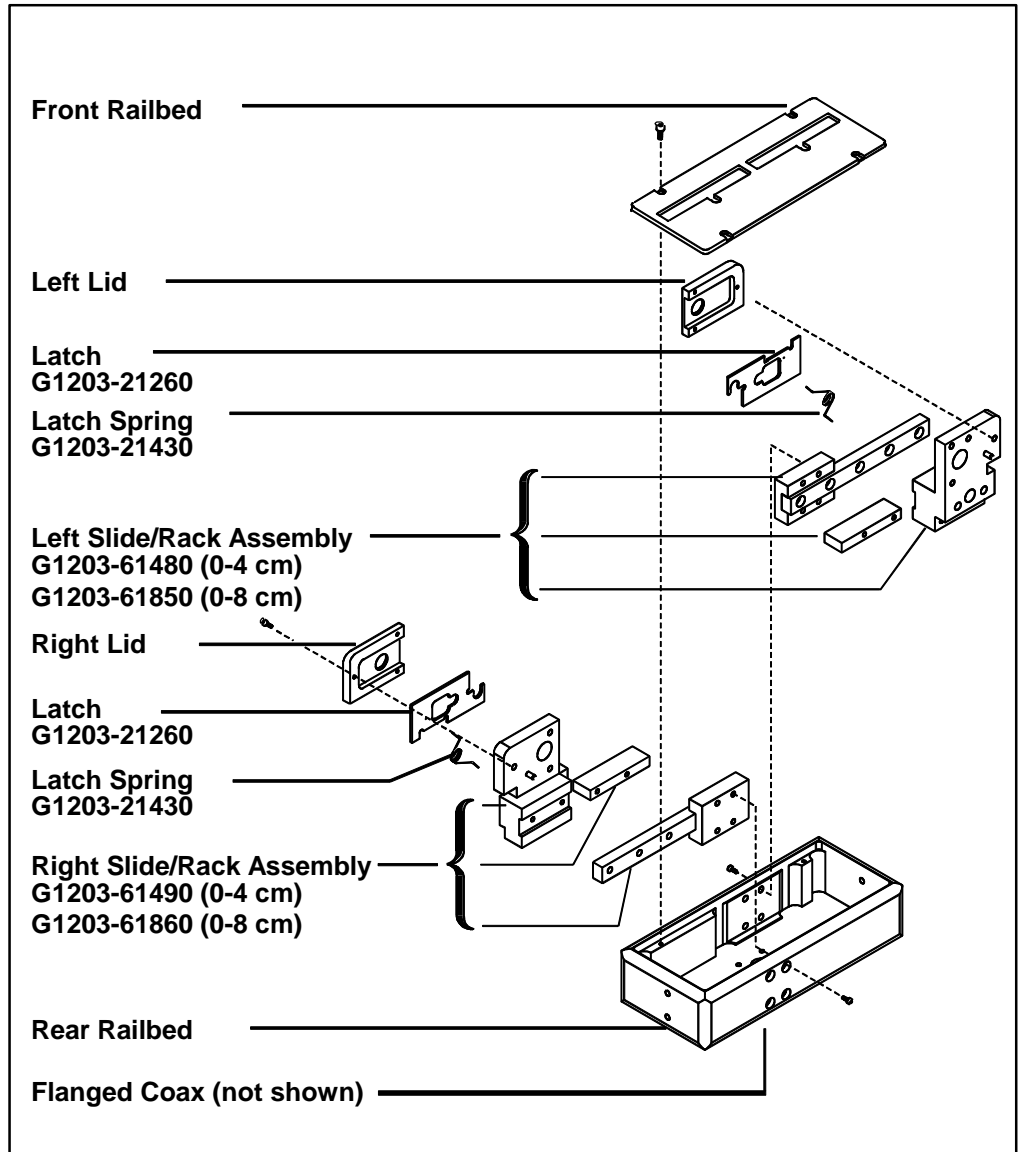

Figure 3-2. Pinch rack assembly

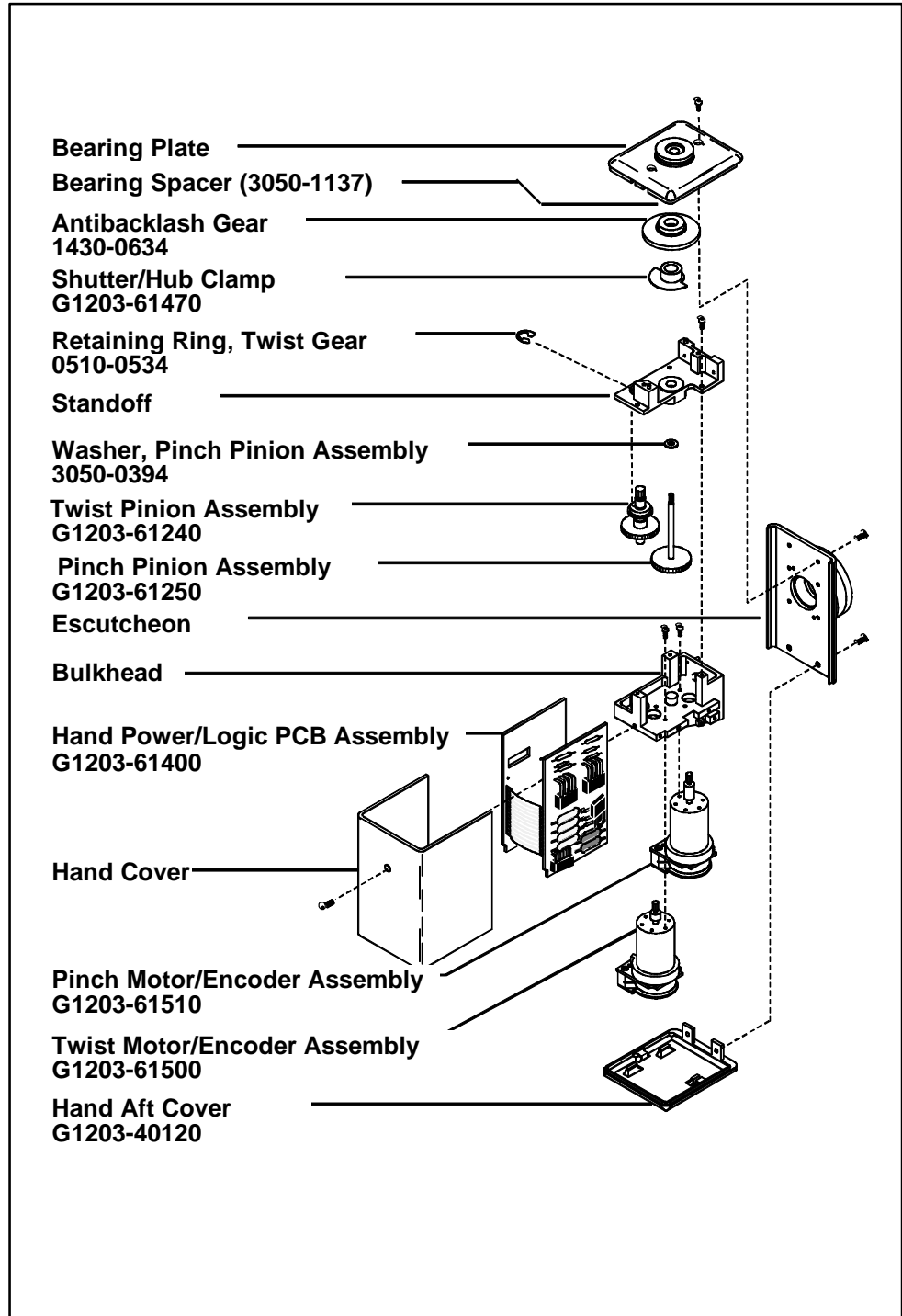

Figure 3-3. Hand assembly.

Pinch Rack

CAUTION

All replacement procedures should be performed with the controller turned off and unplugged. Proper precautions should be taken to protect electronics from damage caused by static discharge.

A. Removing the Pinch Rack

1. Position the arm so that the hand is resting on the upper arm and shoulder with the pinch rack pointing up.
2. Manually move the shells (pinchers) so that they are completely closed.
3. Take off the hand cover by removing the screw with a small Pozidriv screwdriver and sliding the cover off the hand.
4. Remove the two 2.5 mm cap screws that attach the front bearing plate to the standoff.
5. Rotate the pinch rack so that the shutter blade is clear of the optical sensor mounted on the hand power board and hold the pinch rack in this position.
6. Gently lift the bearing plate slightly until the pins release from the hole and the slot in the standoff.
7. Slowly and carefully lift the assembly straight up until it clears the pinch pinion.

B. Replacing the Pinch Rack

1. With the shutter (attached to the hub clamp) facing the back of the hand and the bearing plate pins in the proper orientation, grasp the pinch rack by the shell assemblies (pinchers); at this point it is very important that the pinchers be closed completely (pushed all the way together).
2. Rotate the pinch rack so that the shutter blade will clear the optical sensor.
3. Slowly and carefully slide the coax over the pinch pinion until the first (back) anti-backlash gear makes contact with the twist pinion.
4. Hold the twist spur gear, which protrudes through the slot in the hand logic board, in place and rotate the pinch rack clockwise 4–4.5 teeth.
5. Slip the pinch rack all the way down to engage the second (front) anti-backlash gear; it may be necessary to rotate the pinch rack slightly in the counter-clockwise position so that the teeth are aligned properly.
6. Rotate the bearing plate so that the pins engage the hole and the slot in the hand assembly.
7. Apply Loctite 242 and replace the two screws in the bearing assembly using a 2.5 mm Allen wrench.
8. Rotate the pinch rack and open and close the pinchers to ensure that all gears are engaged (a slight resistance should be felt; twist should rotate through > 360 degrees; grip travel should be at least 40 mm); the shells should be centered when fully closed.
9. Replace the hand cover.

10. Calibrate the arm.

WARNING

Failure to calibrate the robot after servicing will cause unexpected results that can lead to possible serious physical injury and/or damage to the robot, equipment, and other items located in the work cell.

Left/Right Slide Rack Assembly

Caution

All replacement procedures should be performed with the controller turned off and unplugged. Proper precautions should be taken to protect electronics from damage caused by static discharge.

A. Removing the Pinch Rack Slide Assemblies

1. Remove the pinch rack assembly following the procedure outlined in “Removing the Pinch Rack,” steps A1–A7.

NOTE! The latches beneath the covers are spring-loaded and can “pop” out as the latch lid screws are removed. To avoid this, insert a finger blank into the gripper before removing the latch lid screws.

2. Remove the lid screws.
3. Remove the lid(s).
4. While holding down the latch, carefully remove finger blank.
5. Remove the latches and latch springs from the shells.
6. Remove the front rail bed and slide it up over the shells.
7. To remove the slide rack assemblies, unscrew the four retaining screws securing each slide to the rear rail bed and carefully lift out the assembly.

CAUTION

Be carefully not to tilt the slide rack assembly or allow the slide rack rail car to approach the end of the slide rack! Try to keep the slide rack rail car as close to the center of the slide rack as possible. If the slide rack rail car is allowed to approach the end of the slide rack, the slide rack rail car may lose ball bearings resulting in irreparable damage to the assembly.

B. Replacing the Slide Rack Assemblies

1. Replace the slide rack assemblies by placing each in a slot in the rear rail bed; be sure to bottom out the slide bodies gently but firmly while tightening the four retaining screws.
2. Replace the front rail bed, latches and springs, and lids.
3. Replace the pinch rack assembly as outlined in “Replacing the Pinch Rack,” steps B1–B10.

4. Calibrate the arm.

WARNING

Failure to calibrate the robot after servicing will cause unexpected results that can lead to possible serious physical injury and/or damage to the robot, equipment, and other items located in the work cell.

Antibacklash Gear Assembly

Caution

All replacement procedures should be performed with the controller turned off and unplugged. Proper precautions should be taken to protect electronics from damage caused by static discharge.

A. Removing the Antibacklash Gear Assembly

1. Remove the pinch rack assembly following the procedure outlined in “Removing the Pinch Rack,” steps A1–A7.
2. Using a heat gun, warm the old anti-backlash gear until the old glue loosens.
3. Loosen the set screw in the anti-backlash gear and then remove the old gear from the coax shaft. Do not loose the bearing spacer located in front of the anti-backlash gear.
4. Clean the coax shaft with methanol. It is very important to remove all of the old adhesive from the shaft.

B. Installing the Antibacklash Gear Assembly

1. Coat the OD of the coax shaft and the ID of the new anti-backlash gear hole with primer(LocTite 7090). Allow to set for 5 minutes before proceeding.
2. Apply LocTite 609 to the ID of the anti-backlash gear hole and insert onto the coax and push all the way together. Twist the gear to spread the LocTite 609 all the way around the shaft. Tighten the Allen set screw in the anti-backlash gear onto the flat place in the coax shaft. Allow to set for 10 minutes before proceeding.
3. Clean the end of the coax with methanol to remove any excess adhesive.
4. Replace the pinch rack assembly as outlined in “Replacing the Pinch Rack,” steps B1–B10.

Hand Power/Logic PCB Assembly

Caution

All replacement procedures should be performed with the controller turned off and unplugged. Proper precautions should be taken to protect electronics from damage caused by static discharge.

A. Removing the Hand Power/Logic PCB Assembly

1. Take off the hand cover (small Pozidriv) and the hand aft cover (no. 1 Pozidriv).
2. On the hand power board, disconnect the twist and pinch power cables and the forearm-hand cable from P1 connector.
3. Remove the three 2 mm screws on motor driver chips (be carefully not to lose the gray insulator washers associated with each 2 mm screw!) and the two 1.5 mm screws on the hand power board.
4. Lift the power board away from the motor housing and rotate the hand 180 degrees to access the logic board.
5. Remove the two 1.5 mm cap screws on the logic board.
6. Carefully disconnect the logic board from the twist and pinch motor encoder pins by gently pulling up on the board. Take care not to bend the encoder pins on the motor encoders.

B. Replacing the Hand Power/Logic PCB Assembly

1. Position the logic board above the pinch and twist encoder pins so that the sockets in the logic board are aligned with the encoder pins.
2. With the motor encoder pins and sockets aligned, gently push the board down until it is seated on the pins, and replace the two 1.5 mm screws using LocTite 242.
3. Rotate the hand 180 degrees.
4. Apply LocTite 242 and attach the power board to the motor housing using the five cap screws: two 1.5 mm and three 2 mm. Be sure to replace the insulator washers between the 2 mm screws and the motor driver chips.
5. Reconnect the twist motor power cable to P1 (outer 2 pins), the pinch motor power cable to P1 (inner 2 pins), and the forearm-hand cable to P1 (3 center pins) on the power board.
6. Replace the hand aft cover and the hand cover.
7. Calibrate the arm.

WARNING

Failure to calibrate the robot after servicing will cause unexpected results that can lead to possible serious physical injury and/or damage to the robot, equipment, and other items located in the work cell.

Pinch Pinion Assembly

A. Removing the Pinch Pinion Assembly

1. Remove the pinch rack assembly following the procedure outlined in “Removing the Pinch Rack,” steps A1–A7.
2. Remove the hand power/logic PCB assembly as outlined in “Removing the Hand Power/Logic Board Assembly,” steps A1–A6.
3. On the front, forearm side of the hand box, remove the two 2 mm socket head screws that hold the standoff to the escutcheon and the three 2 mm socket head screws that hold the standoff to the bulkhead.
4. Using the jack (Part no. G1203-80320), separate the standoff from the bulkhead; the pinch pinion and the twist pinion assemblies will come with it.

NOTE! Lift the standoff straight up by slowly tightening each screw on the jack a couple of turns. Repeat the process until the standoff is free of the pins on the bulkhead.

5. Remove the retaining ring from the front of the twist pinion assembly.
6. remove the twist pinion assembly.
7. Remove the pinch pinion assembly by sliding it through the standoff bearing.
8. Remove the washer—it may be stuck with lubricant to either the bottom of the standoff bearing or to the top of the spur gear (the large gear on the pinch pinion assembly).

B. Replacing the Pinch Pinion Assembly

1. Place the washer over the shaft of the new pinch pinion assembly.
2. Slide the new pinch pinion assembly through the bearing in the standoff until the washer is in contact with the bottom of the standoff.
3. Replace the twist pinion assembly retaining ring.
4. Replace the standoff assembly by aligning the holes in the standoff with the pins on the bulkhead.
5. Apply LocTite 242 and replace the screws that hold the standoff to the bulkhead and partially tighten each of the three screws in turn to draw the standoff straight onto the pins. (Repeat this process until the standoff is seated securely on the bulkhead.)
6. Apply LocTite 242 and replace the two socket head screws that hold the standoff to the escutcheon.
7. Replace the hand power/logic board assembly as outlined in “Replacing the Hand Power/Logic PCB Assembly,” steps B1–B6, leaving the hand cover off.
8. Replace the pinch rack as outlined in “Replacing the Pinch Rack,” steps B1–B9.
9. Calibrate the arm.

WARNING

Failure to calibrate the robot after servicing will cause unexpected results that can lead to possible serious physical injury and/or damage to the robot, equipment, and other items located in the work cell.

Twist Pinion Assembly

A. Removing the Twist Pinion Assembly

1. Remove the pinch rack assembly following the procedure outlined in “Removing the Pinch Rack,” steps A1–A7.
2. Remove the hand power/logic PCB assembly as outlined in “Removing the Hand Power/Logic PCB Assembly,” steps A1–A6.
3. On the front, forearm side of the hand box, remove the two 2 mm socket head screws that hold the standoff to the escutcheon and the three 2 mm socket head screws that hold the standoff to the bulkhead.
4. Using the jack (Part no. G1203-80320) in the service kit, separate the standoff from the bulkhead; the pinch pinion and the twist pinion assemblies will come with it.

NOTE! Lift the standoff straight up by slowly tightening each screw on the jack a couple of turns. Repeat the process until the standoff is free of the pins on the bulkhead.

5. Remove the retaining ring from the front of the twist pinion assembly.
6. Remove the twist pinion assembly.

B. Replacing the Twist Pinion Assembly

1. Insert the new twist pinion assembly into the bulkhead.
2. Replace the twist pinion assembly retaining ring.
3. Replace the standoff assembly (including the pinch pinion assembly) by aligning the holes in the standoff with the pins on the bulkhead.
4. Apply Loctite 242 and replace the screws that hold the standoff to the bulkhead, and partially tighten each of the three screws in turn to draw the standoff straight onto the pins. (Repeat this process until the standoff is seated securely on the bulkhead.)
5. Apply Loctite 242 and replace the two socket head screws that hold the standoff to the escutcheon.
6. Replace the hand power/logic PCB assembly as outlined in “Replacing the Hand Power/Logic PCB Assembly,” steps B1–B6, leaving the hand cover off.
7. Replace the pinch rack as outlined in “Replacing the Pinch Rack,” steps B1–B9.
8. Calibrate the arm.

WARNING

Failure to calibrate the robot after servicing will cause unexpected results that can lead to possible serious physical injury and/or damage to the robot, equipment, and other items located in the work cell.

Pinch or Twist Motor/Encoder Assembly

A. Removing the Pinch or Twist Motor/Encoder Assembly

1. Remove the pinch rack assembly following the procedure outlined in “Removing the Pinch Rack,” steps A1–A7.
2. Remove the hand power/logic PCB assembly as outlined in “Removing the Hand Power/Logic PCB Assembly,” steps A1–A6.
3. Remove the standoff and pinion assemblies as outlined above in “Removing the Twist Pinion Assembly,” steps A1–A6.
4. Remove either the pinch or twist motor by removing the three screws that hold the appropriate motor assembly to the bulkhead.

B. Replacing the Pinch or Twist Motor Encoder Assembly

1. Apply Loctite 242 and attach the new motor to the bulkhead using the three retaining screws.
2. Replace the twist pinion assembly and the standoff (with the pinch pinion assembly) as outlined in “Replacing the Twist Pinion Assembly,” steps B1–B5.
3. Replace the hand power/logic PCB assembly as outlined in “Replacing the Hand Power/Logic PCB Assembly,” steps B1–B6, leaving the hand cover off.
4. Replace the pinch rack as outlined in “Replacing the Pinch Rack,” steps B1–B9.
5. Calibrate the arm.

WARNING

Failure to calibrate the robot after servicing will cause unexpected results that can lead to possible serious physical injury and/or damage to the robot, equipment, and other items located in the work cell.

Forearm

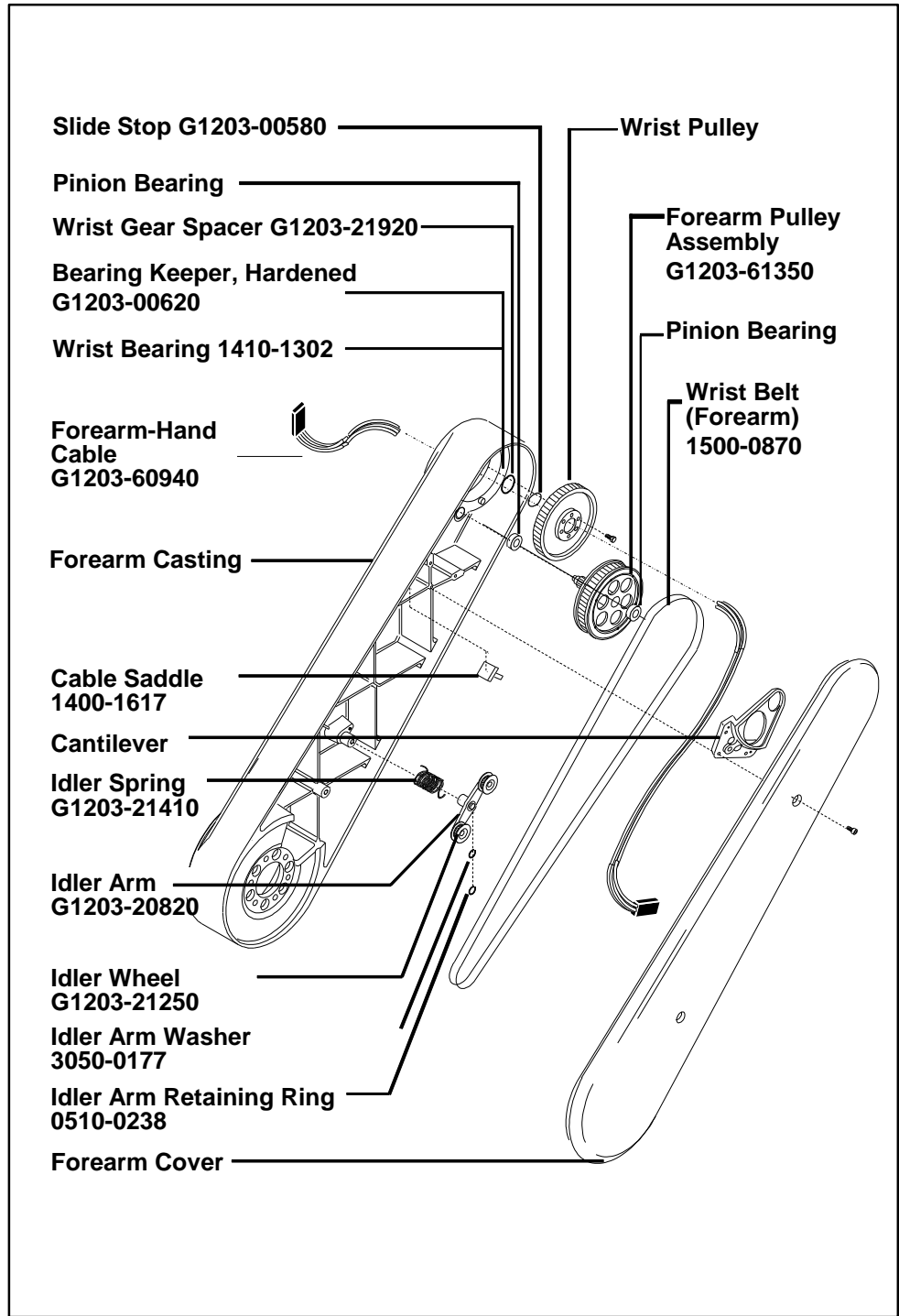

Figure 3-4. Forearm assembly.

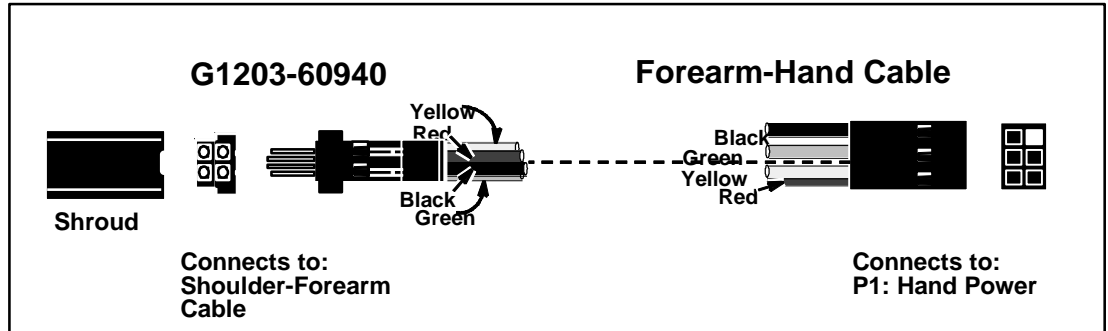

Figure 3-5. Forearm-hand cable.

Wrist Belt (Forearm)

CAUTION

When replacing belts, it is extremely important that they are not forced onto or off pulleys, especially over pulley flanges. Forcing belts in such a manner may cause small nicks, which in turn can severely reduce belt life.

A. Removing the Wrist Belt (Forearm)

1. Take off the forearm cover by removing the two screws with a 2.5 mm Allen wrench.
2. Disconnect the shoulder-forearm cable from the forearm-hand cable.
3. Release the belt tension by rotating the idler bar counterclockwise and moving the belt away from the idler wheels.
4. Slip the belt off the transfer shaft pinion at the elbow joint.
5. Remove the belt by slipping the other end off the forearm pulley assembly..

B. Replacing the Wrist Belt (Forearm)

1. Slip the new belt over the forearm pulley assembly.
2. Slip the other end of the belt over the transfer shaft pinion protruding through the elbow joint.
3. Reposition the idler arm (rotate 225 degrees clockwise) to take up slack in the belt.
4. Reconnect the shoulder-forearm cable to the forearm-hand cable. Replace cables in the cable saddles.
5. Replace the forearm cover.
6. Calibrate the arm.

WARNING

Failure to calibrate the robot after servicing will cause unexpected results that can lead to possible serious physical injury and/or damage to the robot, equipment, and other items located in the work cell.

Idler Bar and Idler Spring

A. Removing the Idler Bar and Idler Spring

1. Take off the forearm cover by removing the two screws with a 2.5 mm Allen wrench.
2. Release the belt tension by rotating the idler bar counterclockwise and moving the belt away from the idler wheels.
3. Slide the idler wheels off the idler arm and release the idler arm tension.
4. Remove the idler arm retaining ring from the center of the idler arm. Take care not to lose the washer that goes between the idler arm and the idler arm retaining ring.
5. Grab the idler spring and slide the idler bar off its shaft, leaving the spring on the shaft.
6. Remove the idler spring if necessary.

B. Replacing the Idler Bar and Idler Spring

1. Replace the idler spring if necessary.
2. Slide the idler bar over the shaft and insert the spring into the hole in the idler bar.
3. Place the washer onto the idler arm post.
4. Replace the retaining ring (a new retaining ring is recommended).
5. Rotate the idler arm 225 degrees clockwise, replace the idler wheels (with the flange of the bushing facing outwards) on the idler arm, engage the wrist belt (forearm) in the idler wheels, and release the idler arm to take up slack in the belt.
6. Replace the forearm cover.
7. Calibrate the arm.

WARNING

Failure to calibrate the robot after servicing will cause unexpected results that can lead to possible serious physical injury and/or damage to the robot, equipment, and other items located in the work cell.

Idler Wheel(s)

A. Removing the Idler Wheel(s)

1. Take off the forearm cover by removing the two screws with a 2.5 mm Allen wrench.
2. Release the belt tension by rotating the idler bar clockwise.
3. Pull the idler wheels off the idler posts.

B. Replacing the Idler Wheel(s)

1. Push the new idler wheels onto the idler posts (with the flange of the bushing facing outwards).
2. Engage the wrist belt (forearm) in the idler wheels by releasing the idler bar to take up slack in the belt.
3. Replace the forearm cover.
4. Calibrate the arm.

WARNING

Failure to calibrate the robot after servicing will cause unexpected results that can lead to possible serious physical injury and/or damage to the robot, equipment, and other items located in the work cell.

Forearm Pulley Assembly

A. Removing the Forearm Pulley Assembly

1. Remove the forearm cover by removing the two screw with 2.5 mm Allen wrench.
2. Remove the wrist belt (forearm) as described in “Removing the Wrist Belt (Forearm),” steps A1–A5.
3. Remove the three screws that secure the cantilever to the forearm casting.
4. Remove the forearm pulley assembly and the cantilever from the forearm.
5. Separate the cantilever and the forearm pulley assembly.
6. Remove one pinion bearing from the cantilever and the other from the forearm casting.

B. Replacing the Forearm Pulley Assembly

1. Press one pinion bearing into the cantilever and another into the forearm casting.
2. Insert the shaft of the wrist pulley assembly shaft into the pinion bearing located in the forearm casting.
3. Using Loctite 242, secure the forearm pulley assembly by installing the cantilever using three retaining screws (do not tighten the screws completely).
4. Slip the wrist belt over the forearm pulley assembly.
5. Slip the other end of the belt over the transfer shaft pinion protruding through the elbow joint.
6. Reposition the idler bar (rotate 225 degrees clockwise) to take up slack in the belt.
7. Reconnect the shoulder-forearm cable to the forearm-hand cable. Replace cables in the cables saddles.
8. Measure the wrist backlash as described below.
 - a. Locate a convenient rail position to work on the robot.
 - b. Enable power to the arm and perform a rough calibration (level by eye).
 - c. From the Dictionary Manager command line, execute the following command: `MOVETO ,30,0,0,0,0` (default rail to current position).
 - d. Place the digital level sensor on the hand box as if the wrist was being calibrated.
 - e. While observing the wrist belt, grasp the hand box and gently rotate it clockwise until slight resistance is felt (a few tenths of a degree). Do NOT FORCE the axis beyond this point. The wrist belt should not move during this procedure.
 - f. Record the reading from the level, including the minus sign if present.
 - g. While observing the wrist belt, grasp the hand box and rotate it counterclockwise until slight resistance is felt (a few tenths of a degree). Do NOT FORCE the axis beyond this point. The wrist belt should not move during this procedure.

- h. Record the reading from the level, including the minus sign if present.
 - i. Subtract the second reading from the first to get a measurement of the backlash in the wrist joint. The absolute value should be between 0.04 and 0.20 degrees. If the value falls outside the range, perform the adjustment procedure described in Section C. Otherwise, proceed to step j.
 - j. Set the bend to -180 degrees (set the twist to 90 degrees first) and repeat steps d-i.
9. Replace the forearm cover.
 10. Calibrate the arm.

WARNING

Failure to calibrate the robot after servicing will cause unexpected results that can lead to possible serious physical injury and/or damage to the robot, equipment, and other items located in the work cell.

C. Wrist Backlash Adjustment Procedure

1. Individually remove the three screws that attach the cantilever to the forearm casting. Apply Loctite 242 to each and then reinstall them but do not tighten (i.e. leave the screws loose).
2. Insert two flat blade screwdrivers into the two holes at the rear of the cantilever and move it towards the forearm pulley (towards the forearm pulley reduces the wrist backlash; away from the forearm pulley increases the wrist backlash).
3. Holding the cantilever in the desired position with the screwdrivers, tighten the three mounting screws.
4. Measure the wrist backlash as described in steps B8a-B8j above.
5. Replace the forearm cover.
6. Calibrate the arm.

WARNING

Failure to calibrate the robot after servicing will cause unexpected results that can lead to possible serious physical injury and/or damage to the robot, equipment, and other items located in the work cell.

Wrist Bearing Assembly

A. Removing the Wrist Bearing.

1. Remove the forearm pulley assembly as described in “Removing the Forearm Pulley Assembly,” steps A1–A6.
2. Disconnect the shoulder-forearm cable from the forearm-hand cable, just above the elbow joint in the forearm casting.
3. Free the cable from the cable saddles that lie on the inside of the forearm casting.
4. Remove the three 2 mm Allen screws from the wrist pulley. Then remove pulley by slowly pulling straight out on the hand box. The wrist gear spacer and slide stop are also freed when removing the wrist pulley.
5. Remove 6 screws from the bearing keeper and remove the wrist bearing and bearing keeper.

B. Installing the Wrist Bearing

1. Insert wrist bearing into opening in the forearm casting. Install six 2 mm screws in the bearing keeper. These screws should be tightened slowly and using an across pattern.
2. Insert the hand box assembly into the wrist bearing. Then slide wrist gear spacer and slide stop over the hand box shaft.
3. Install the wrist pulley on the hand box shaft using three 2 mm Allen screws. Before tightening turn hand box to the maximum clockwise position(2 o'clock). If the hand box turns farther then this positions adjust position of the wrist gear spacer and bearing keeper.
4. Turn the hand box fully counter-clockwise and clockwise so see if their is any binding as it turns. If their is any binding remove the wrist pulley and adjust the screws holding the wrist bearing.
5. Repeat steps 3 and 4 until a smooth motion is obtained and the hard stops are correct.
6. Install forearm-hand cable into saddle. Reconnect the forearm-hand cable to the shoulder-forearm cable.
7. Install the Forearm pulley assembly as described in “Replacing the Forearm Pulley Assembly,” steps B1–B10.

Forearm-Hand Cable

CAUTION

Carefully observe the routing of the cable prior to performing this procedure. It is critical that it be routed in exactly the same manner. Care must be taken to prevent the cable from coming in contact with any moving parts (e.g., belts).

A. Removing the Forearm-Hand Cable

1. Remove the forearm cover by removing the two screws with 2.5 mm Allen wrench.
2. Disconnect the shoulder-forearm cable from the forearm-hand cable, just above the elbow joint in the forearm casting.

NOTE! The shroud should be locked onto the forearm-hand cable connector. If it is locked onto the shoulder-forearm cable connector, a new shroud will be required.

3. Free the cable from the cable saddles that lie on the inside of the forearm casting.
4. Remove the hand cover (small Pozidriv) and the hand aft cover (no. 1 Pozidriv).
5. On the hand power board, disconnect the forearm-hand cable and the twist and pinch power cables from P1.
6. Remove the three 2 mm screws on the motor drive chips (be careful not to lose the gray insulator washers associated with each 2 mm screw!) and the two 1.5 mm cap screws on the hand power board.
7. Lift the power board away from the motor housing and rotate the hand 180 degrees to access the logic board.
8. Remove the two 1.5 mm screws on the logic board.

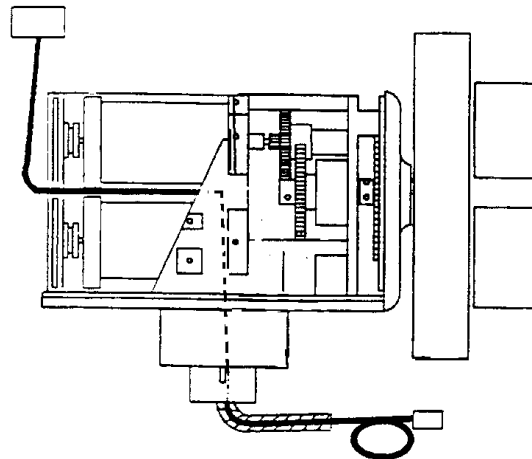

Figure 3-6. Forearm-hand cable routing

9. Disconnect the logic board from the twist-and-pinch motor encoder pins by gently pulling up on the board. Take extreme care not to bend the encoder pins on the motor encoders. Set the board aside.

CAUTION

Carefully observe the routing of the cable through the hand prior to performing this procedure. Refer to Figure 3-6.

10. Cut the cable at the wrist joint and remove the two halves of the cut forearm-hand cable. Save the black plastic grommet.

B. Replacing the Forearm-Hand Cable

1. Remove the large connector from the forearm-hand cable being careful not to break the pin keepers. Write down the wire colors and pin numbers before removing the pins.
2. Route the loose ends through the wrist joint out the lower part of the hand box opening. Refer to Figure 3-6.
3. Insert pins back into the original connector shell.
4. Position the hand logic board above the twist-and-pinch encoder pins so that the sockets in the logic board are aligned with the encoder pins.
5. With the pins and sockets aligned, gently push the board down until it rests on the motor housing. Reattach with the two mounting screws.
6. Rotate the hand 180 degrees.
7. Insert the forearm-hand cable, the two motor power cables, and the spiral wrap in the grommet and place grommet in the notch in the bulkhead.
8. Position the hand power board so it clamps the end of the spiral wrap between the board and the escutcheon (as shown in the Figure 3-6) and traps the grommet in the notch.
9. Attach the hand power board to the bulkhead using the two 1.5 mm screws and the three 2.0 mm screws on the motor drive chips (be certain to replace the gray insulator washers between each 2 mm screw and the motor drive chip!).
10. Ensure the plastic grommet is seated in the notch between the two motors and the spiral wrap is clamped between board and bulkhead.
11. Reconnect the forearm-hand cable to the center of P1 on the hand power board, the twist power cable to the left portion of P1 (outer edge of the board), and the pinch power to the right portion of P1.
12. Mark the cable about 60 mm from where it passes through the wrist joint.
13. Insert the cable at the mark into the first cable saddle in the forearm casting. This should produce a nice service loop for full rotation of the wrist during operation.

CAUTION

Do not twist the cable during installation.

14. Reconnect the forearm-hand cable to the shoulder-forearm cable just above the elbow joint in the forearm casting.

NOTE! The shroud should be locked onto the forearm-hand cable connector. If it is locked onto the old shoulder-forearm cable connector, use a replacement from the service kit.

15. Manually rotate the wrist through its entire range of motion to check for smooth operation.
16. Secure the cable in the metal U-shield that lies on the inside of the forearm casting as well as in the remaining cable saddles.
17. Replace the hand cover (small Pozidriv) and the hand aft cover (no. 1 Pozidriv).
18. Replace the forearm cover.
19. Calibrate the arm.

WARNING

Failure to calibrate the robot after servicing will cause unexpected results that can lead to possible serious physical injury and/or damage to the robot, equipment, and other items located in the work cell.

Upper Arm

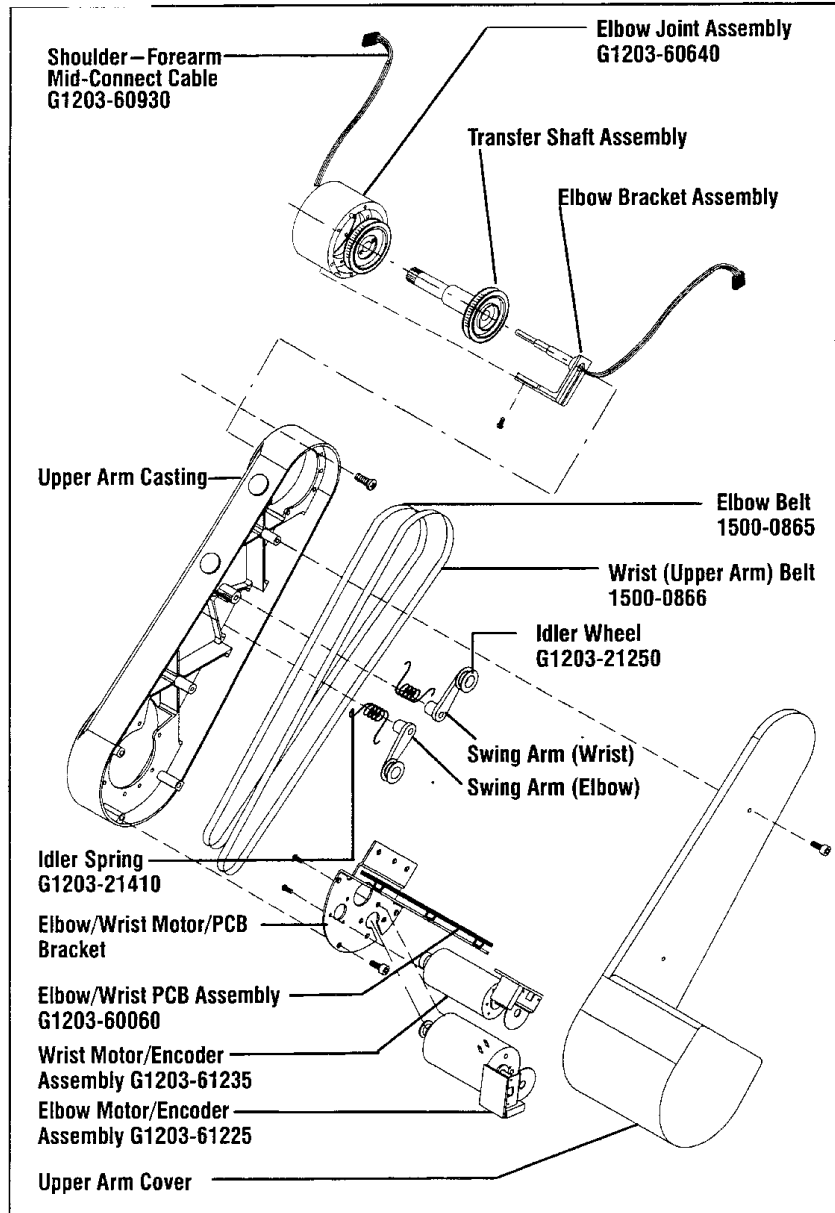

re 3-7. Upper arm assembly.

Fig

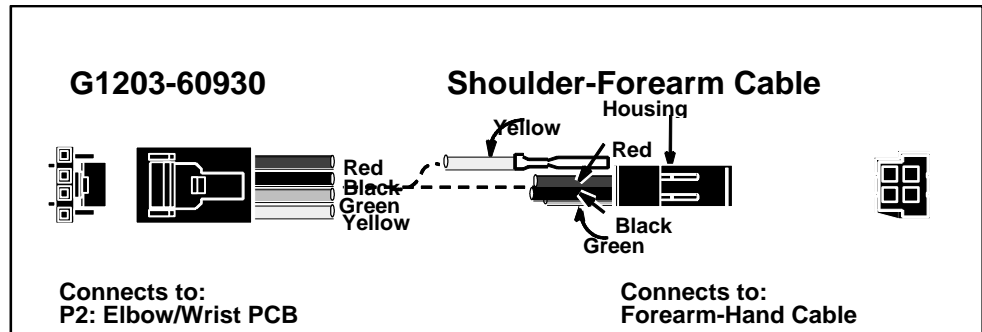

Figure 3-8. Shoulder-forearm cable.

Elbow/Wrist Motor/Encoder Assembly

CAUTION

All replacement procedures should be performed with the controller turned off and unplugged. Proper precautions should be taken to protect electronics from damage caused by static discharge.

A. Removing the Wrist Motor/Encoder Assembly

1. Remove the upper arm cover by removing the two screws with a 2.5 mm Allen wrench.
2. Release tension on the belts by disengaging them from the swing arm.
 - a. Rotate the wrist belt swing arm (top, outer swing arm) clockwise until the belt no longer touches the swing arm pulley; slowly release the swing arm so that the wrist (upper arm) belt is free of the pulley.
 - b. Rotate the elbow belt swing arm (bottom, inner swing arm) clockwise until the belt no longer touches the swing arm pulley; slowly release the swing arm so that the elbow belt is free of the pulley.
3. Disconnect the motor power and encoder cables from P6 and P7, respectively, on the elbow/wrist PCB assembly.
4. Disconnect the torso-shoulder cable from P1 and the shoulder-forearm cable from P2 on the elbow/wrist PCB assembly.
5. Using a 3 mm Allen wrench, remove the three bracket mounting screws and lift the bracket assembly to disengage the belts.
6. Using a no. 1 Pozidriv screwdriver, unscrew the three motor-mounting screws and slide the motor shaft (pulley end) through the hole in the bracket (the wrist motor/encoder assembly is the smaller of the two motors).

B. Removing the Elbow Motor/Encoder Assembly

1. Take off the upper arm cover by removing the two screws with a 2.5 mm Allen wrench.
2. Release tension on the belts by disengaging them from the swing arm.
 - a. Rotate the wrist belt swing arm (top, outer swing arm) clockwise until the belt no longer touches the swing arm pulley; slowly release the swing arm so that the wrist (upper arm) belt is free of the pulley.
 - b. Rotate the elbow belt swing arm (bottom, inner swing arm) clockwise until the belt no longer touches the swing arm pulley; slowly release the swing arm so that the elbow belt is free of the pulley.
3. Disconnect the motor power and encoder cables from P5 and P3, respectively, on the elbow/wrist PCB assembly.
4. Disconnect the torso-shoulder cable from P1 and the shoulder-forearm cable from P2 on the elbow/wrist PCB assembly.
5. Using a 3 mm Allen wrench, remove the three bracket mounting screws and lift the bracket assembly to disengage the belts.
6. Note the orientation of the motor/encoder assembly relative to the wrist/elbow PCB.
7. Using a no. 2 Pozidriv screwdriver, unscrew the four motor-mounting screws for the motor and slide the motor shaft down through the slot in the bracket (the elbow motor/encoder assembly is the larger of the two motors).

C. Replacing the Elbow/Wrist Motor/Encoder Assembly

1. Slide the appropriate motor shaft through the slot or hole in the mounting bracket.
2. Rotate the wrist motor assembly so that the back of the encoder board is facing the top of the bracket and the screw holes in the bracket and motor are aligned.
3. Rotate the elbow motor assembly so that the top of the encoder board is pointing approximately to the eight o'clock position (orientation of the motor should match the position noted in step B6, above).
4. Attach the motor assembly to the bracket with the proper mounting screws.
5. Slip the torso-shoulder cable from shoulder through the slot in the front of the bracket.
6. Slip the belts on their respective gears and pinions.
7. Apply Loctite 242 and loosely attach the bracket to the arm using the three bracket-mounting screws (do not tighten the screws completely at this time).
8. Tension the belts by engaging the swing arms (the upper swing arm supplies tension to the wrist (upper arm) belt, while the lower swing arm supplies tension for the elbow belt).
9. Complete the belt tensioning procedure by pushing down on the wrist motor side of the bracket until both belts are taut, then tighten the three bracket-mounting screws.

10. Connect the motor power and encoder cables to the appropriate pins (see step A3 and/or B3, above) on the elbow/wrist PCB assembly.
11. Connect the torso-shoulder cable to P1 and the shoulder-forearm cable to P2 on the elbow/wrist PCB assembly.
12. Replace the upper arm cover.
13. Calibrate the arm.

WARNING

Failure to calibrate the robot after servicing will cause unexpected results that can lead to possible serious physical injury and/or damage to the robot, equipment, and other items located in the work cell.

Elbow/Wrist PCB Assembly

CAUTION

All replacement procedures should be performed with the controller turned off and unplugged. Proper precautions should be taken to protect electronics from damage caused by static discharge.

A. Removing the Elbow/Wrist PCB Assembly

1. Take off the upper arm cover by removing the two screws with a 2.5 mm Allen wrench.
2. Disconnect the wrist motor power and encoder cables from P6 and P7, respectively, on the elbow/wrist PCB assembly.
3. Disconnect the elbow motor power and encoder cables from P5 and P3, respectively, on the elbow/wrist PCB assembly.
4. Disconnect the shoulder-forearm cable and torso-shoulder cable from P2 and P1, respectively, on the PCB assembly.
5. Using a 2.5 mm Allen wrench, remove the three heat sink screws and the two PCB-to-bracket-mounting screws and lift the elbow/wrist PCB assembly from the bracket.

B. Replacing the Elbow/Wrist PCB Assembly

1. Place the new board on the bracket and connect the heat sink screws and elbow/wrist PCB assembly-to-bracket-mounting screws.
2. Connect the motor power and encoder cables to the appropriate pins (see steps A2 and A3, above) on the elbow/wrist PCB above.
3. Connect the shoulder-forearm cable and the torso-shoulder cable to the appropriate pins (see step A4, above) on the elbow/wrist PCB assembly.
4. Replace the upper arm cover.
5. Calibrate the arm.

WARNING

Failure to calibrate the robot after servicing will cause unexpected results that can lead to possible serious physical injury and/or damage to the robot, equipment, and other items located in the work cell.

Elbow Belt and Wrist (Upper Arm) Belt

WARNING

All replacement procedures should be performed with the controller turned off and unplugged. Proper precautions should be taken to protect electronics from damage caused by static discharge.

CAUTION

When replacing belts, it is extremely important that they are not forced on or off pulleys, especially over pulley flanges. Forcing belts in such a manner may cause small nicks, which in turn can severely reduce belt life.

A. Removing the Elbow Belt and Wrist (Upper Arm) Belt

1. Take off the upper arm cover by removing the two screws with a 2.5 mm Allen wrench
2. Release tension on the belts by disengaging them from the swing arm.
 - a. Rotate the wrist belt swing arm (top, outer swing arm) clockwise until the belt no longer touches the swing arm pulley; slowly release the swing arm so that the wrist (upper arm) belt is free of the pulley.
 - b. Rotate the elbow belt swing arm (bottom, inner swing arm) clockwise until the belt no longer touches the swing arm pulley; slowly release the swing arm so that the elbow belt is free of the pulley.
3. Using a 3 mm Allen wrench, individually remove the three bracket-mounting screws, apply Loctite 242 to each, and loosely replace one screw.
4. Remove the elbow belt and wrist (upper arm) belt.

B. Replacing the Elbow Belt and Wrist (Upper Arm) Belt

1. Slip the new belts on their respective gears and pinions (the inner belt is the elbow belt and goes directly to the elbow joint at one end and the larger motor pinion on the other; the outer belt is the wrist (upper arm) belt and goes to the wrist pulley at one end and the smaller motor pinion on the other). See Figure 3-7.
2. Install the remaining two 3 mm screws in the mounting bracket, and then tighten the three bracket-mounting screws
3. Tension the belts by engaging the swing arms (the upper swing arm supplies tension to the wrist (upper arm) belt, while the lower swing arm supplies tension for the elbow belt).
4. Replace the upper arm cover.
5. Calibrate the arm.

WARNING

Failure to calibrate the robot after servicing will cause unexpected results that can lead to possible serious physical injury and/or damage to the robot, equipment, and other items located in the work cell.

Idler Swing Arm and Spring

CAUTION

All replacement procedures should be performed with the controller turned off and unplugged. Proper precautions should be taken to protect electronics from damage caused by static discharge.

A. Removing the Idler Swing Arm and Spring

1. Take off the upper arm cover by removing the two cap screws with a 2.5 mm Allen wrench.
2. Rotate the idler arm to disengage the wrist or elbow belt.
 - a. Rotate the wrist belt idler arm (top, outer idler arm) clockwise until the belt no longer touches the idler wheel; slowly release the idler arm so that the wrist (upper arm) belt is free of the wheel.
 - b. Rotate the elbow belt idler arm (bottom, inner idler arm) clockwise until the belt no longer touches the idler wheel; slowly release the idler arm so that the elbow belt is free of the wheel.
3. Remove the retaining ring that holds the idler swing arm to the post.
4. Remove the washer from the swing arm post.
5. Grab the spring and slide the idler arm off the post, leaving the spring on the post.
6. If necessary, remove the spring.

B. Replacing the Idler Swing Arm and Spring

1. Replace the spring if necessary.
2. Slide the swing arm over the post shaft and insert the spring into the hole in the swing arm.
3. Replace the washer onto the swing arm post.
4. Replace the retaining ring (a new retaining ring is recommended).
5. Rotate the swing arm, engage the belt in the idler wheel, and release the swing arm to take up slack in the belt.
6. Replace the upper arm cover.
7. Calibrate the arm.

WARNING

Failure to calibrate the robot after servicing will cause unexpected results that can lead to possible serious physical injury and/or damage to the robot, equipment, and other items located in the work cell.

Idler Wheel

CAUTION

All replacement procedures should be performed with the controller turned off and unplugged. Proper precautions should be taken to protect electronics from damage caused by static discharge.

A. Removing the Idler Wheel

1. Take off the upper arm cover by removing the two screws with a 2.5 mm Allen wrench.
2. Release the belt tension by rotating the swing arm and moving the belt away from the idler wheel.
3. Pull the idler wheel off the idler post.

B. Replacing the Idler Wheel

1. Slide the new idler wheel onto the swing arm.
2. Rotate the swing arm, engage the appropriate belt in the idler wheel, and release the swing arm to take up slack in the belt.
3. Replace the upper arm cover.
4. Calibrate the arm.

WARNING

Failure to calibrate the robot after servicing will cause unexpected results that can lead to possible serious physical injury and/or damage to the robot, equipment, and other items located in the work cell.

Elbow Joint

CAUTION

All replacement procedures should be performed with the controller turned off and unplugged. Proper precautions should be taken to protect electronics from damage caused by static discharge.

A. Removing the Elbow Joint

1. Remove the upper arm and forearm covers.
2. Remove the elbow belt and wrist (upper arm) belt and the wrist (forearm) belt (it will be necessary to loosen or remove the elbow/wrist PCB bracket).
3. Disconnect the shoulder-forearm cable from P2 on the elbow/wrist PCB assembly.
4. Disconnect the shoulder-forearm cable from the forearm-hand cable.
5. On the forearm side of the joint, use a 2.5 mm Allen wrench to remove the four screws that connect the forearm and hand assemblies to the joint and remove the entire forearm-hand assembly.

CAUTION

Hold the forearm in place as you remove the retaining screws. Do not allow the dowel pins to bear the full weight of the assembly! Take care to pull the forearm straight out so as not to damage the dowel pin hole and slot or the joint.

6. On the upper arm side of the joint, use a 2.5 mm Allen wrench to remove the six screws that connect the upper arm casting to the joint and remove the joint from the forearm side.

CAUTION

Hold the joint in place as you remove the retaining screws. Do not allow the dowel pins to bear the full weight of the joint assembly! Take care to pull the elbow, straight out so as not to damage the dowel pin hole and slot or the joint.

B. Replacing the Elbow Joint

1. Insert the new joint into the upper arm casting from the forearm side of the joint by lining up the dowel pins in the elbow joint with the corresponding mating hole and slot in the upper arm casting; secure the joint with the six retaining screws using an adjustable torque screwdriver set for 10 in-lb.; use Loctite 242 on the screws.

CAUTION

Do not force the pins in the hole and slot! Be sure to use the correct screws! Screws larger than 6 mm can cause severe damage to the joint!

CAUTION

Hold the joint in place as you replace the retaining screws. Do not allow the dowel pins to bear the full weight of the joint assembly! Take care to hold the elbow straight so as not to damage the dowel pin hole and slot or the joint.

2. Slip the forearm assembly over the joint by lining up the dowel pins in the elbow joint with the corresponding mating hole and slot in the forearm casting; secure it with the four retaining screws using an adjustable torque screwdriver set for 10 in-lb.; use Loctite 242 on the screws.

CAUTION

Do not force the pins in the hole and slot! Be sure to use the correct screws! Screws larger than 10 mm can cause severe damage to the joint!

CAUTION

Hold the forearm in place as you replace the retaining screws. Do not allow the dowel pins to bear the full weight of the assembly! Take care to hold the forearm straight so as not to damage the dowel pin hole and slot or the joint.

3. Connect the shoulder-forearm cable to the forearm-hand cable.
4. Connect the shoulder-forearm cable to P2 on the wrist/elbow PCB assembly.
5. Replace the wrist (forearm) belt and elbow belt and wrist (upper arm) belt.
6. Replace the upper arm and forearm covers.
7. Calibrate the arm.

WARNING

Failure to calibrate the robot after servicing will cause unexpected results that can lead to possible serious physical injury and/or damage to the robot, equipment, and other items located in the work cell.

Shoulder-Forearm Cable

CAUTION

Carefully observe the routing of the cable prior to performing this procedure. It is critical that it be routed in exactly the same manner. Care must be taken to prevent the cable from coming in contact with any moving parts (e.g., belts).

CAUTION

All replacement procedures should be performed with the controller turned off and unplugged. Proper precautions should be taken to protect electronics from damage caused by static discharge.

A. Removing the Shoulder-Forearm Cable

1. Remove the upper arm and forearm covers by removing the two screws from each cover using a 2.5 mm Allen wrench.
2. Disconnect the shoulder-forearm cable from P2 on the elbow/wrist PCB assembly.
3. Clip the cable ties that secure the shoulder-forearm cable to the elbow/wrist PCB bracket and the elbow joint bracket.
4. Free the cable from the wire traps that lie on the inside of the upper arm casting.
5. Disconnect the shoulder-forearm cable from the forearm-hand cable, just above the elbow joint in the forearm casting.

NOTE! The shroud should be locked onto the forearm-hand cable connector. If it is locked onto the shoulder-forearm cable connector disregard the shroud shipped with the new cable and use the old shroud.

6. Cut off the connector and pull the cable through the elbow joint from the upper arm side of the joint.

B. Replacing the Shoulder-Forearm Cable

1. Thread the end of the new cable without the connector through the elbow joint from the upper arm side of the joint.
2. Insert the four wires into the supplied connector in the order shown in figure 3-11.
3. Reconnect the shoulder-forearm cable to the forearm-hand cable, using the connector shroud if necessary.
4. Reconnect the shoulder-forearm cable to P2 on the elbow/wrist PCB assembly.
5. Secure the cable to the elbow/wrist PCB bracket and elbow joint bracket with new cable ties.
6. Secure the cable in each of the cable saddles located in both the upper arm and forearm castings.
7. Replace the upper arm and forearm covers.

Torso

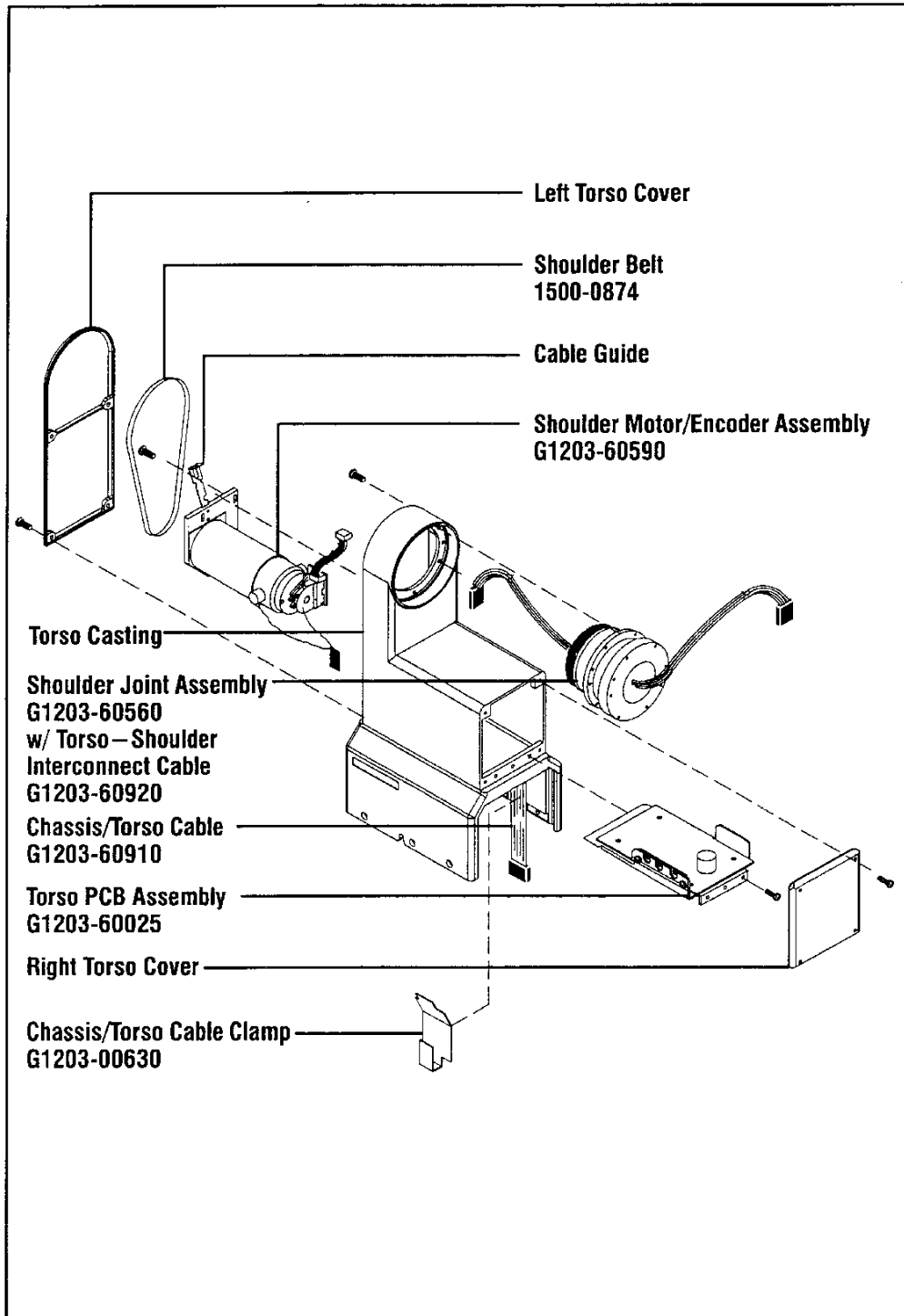

Figure 3-9. Torso assembly.

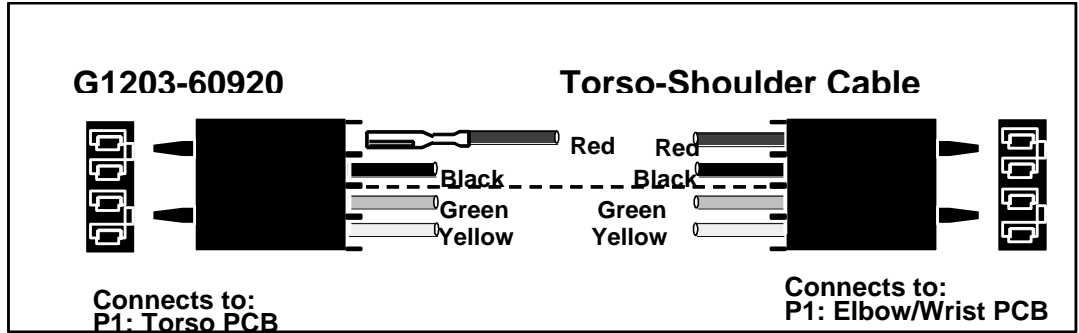

Figure 3-10. Torso-Shoulder cable.

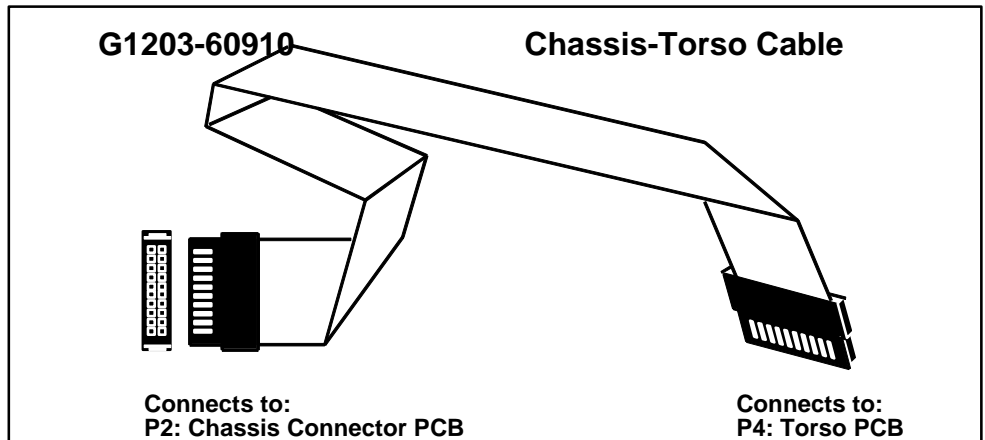

Figure 3-11. Chassis/Torso cable.

Shoulder Motor/Encoder Assembly

CAUTION

All replacement procedures should be performed with the controller turned off and unplugged. Proper precautions should be taken to protect electronics from damage caused by static discharge.

A. Removing the Shoulder Motor/Encoder Assembly

1. Using a 2.5 mm Allen wrench, take off both torso covers by removing the eight screws (four in each cover).
2. Disconnect the shoulder motor power and encoder cables from pins P5 and P3, respectively, on the torso PCB assembly.
3. Using a 2.5 mm Allen wrench, remove the cable guide from the shoulder motor bracket.
4. Using a 2.5 mm Allen wrench, slightly loosen the three screws that hold the shoulder motor-mounting bracket to the torso to release tension on the shoulder belt.
5. Remove the shoulder belt.
6. Remove the shoulder motor-mounting bracket screws and lift the motor/encoder assembly up and out of the torso.

CAUTION

Support the weight of the shoulder motor/encoder assembly to prevent it from falling on the torso PCB.

B. Replacing the Shoulder Motor/Encoder Assembly

1. Apply LocTite 242 to the shoulder mounting screws and attach the shoulder motor assembly to the torso casting (do not tighten completely).
2. Slip the shoulder belt over the shoulder motor pinion and the shoulder joint.
3. Tighten the belt by pushing down on the shoulder motor-mounting bracket until the belt is taut; significant force is not required because the weight of the motor is nearly sufficient to achieve adequate belt tension.
4. Tighten the bracket screws completely.
5. Connect the shoulder motor power and encoder cables to pins P5 and P3, respectively, on the torso PCB assembly.
6. Replace the cable guide on the motor bracket.
7. Replace both torso covers.
8. Calibrate the arm.

WARNING

Failure to calibrate the robot after servicing will cause unexpected results that can lead to possible serious physical injury and/or damage to the robot, equipment, and other items located in the work cell.

Torso PCB Assembly

CAUTION

All replacement procedures should be performed with the controller turned off and unplugged. Proper precautions should be taken to protect electronics from damage caused by static discharge.

A. Removing the Torso PCB

1. Using a 2.5 mm Allen wrench, take off both torso covers by removing the eight cap screws (four in each cover).
2. Disconnect the shoulder motor power and encoder cables from P5 and P3, respectively, on the torso PCB assembly.
3. Disconnect the torso-shoulder cable from P1 on the torso PCB assembly.
4. Disconnect the chassis/torso cable from P4 on the torso PCB assembly.
5. Using a no. 2 Pozidriv screwdriver, unscrew the three bracket-mounting screws and slide the torso PCB assembly and torso bracket out of the torso casting.

B. Replacing the Torso PCB

1. Slide the new torso PCB assembly and torso bracket into the slot in the torso casting. Apply Loctite 242 and replace the bracket-mounting screws.
2. Connect the shoulder motor power and encoder cables, the torso-shoulder cable, and the chassis/torso ribbon cables to their appropriate pins (see steps A2–A4) on the torso PCB assembly.
3. Replace the torso covers.

Shoulder Belt

CAUTION

All replacement procedures should be performed with the controller turned off and unplugged. Proper precautions should be taken to protect electronics from damage caused by static discharge.

WARNING

When replacing belts, it is extremely important that they are not forced on or off pulleys, especially over pulley flanges. Forcing belts in such a manner may cause small nicks which, in turn, can severely reduce belt life.

A. Removing the Shoulder Belt

1. Using a 2.5 mm Allen wrench, take off the larger torso cover by removing the four screws.
2. Using a 2.5 mm Allen wrench, individually remove the three screws that hold the shoulder motor-mounting bracket to the torso and apply Loctite 242 to each. Replace each screw but do not tighten.
3. Remove the shoulder belt.

B. Replacing the Shoulder Belt

1. Slip the new shoulder belt over the shoulder motor pinion and the shoulder joint.
2. Tighten the belt by pushing down on the shoulder motor-mounting bracket until the belt is taut; significant force is not required because the weight of the motor is nearly sufficient to achieve adequate belt tension.
3. Tighten the shoulder motor-mounting bracket screws.
4. Replace the torso cover.
5. Calibrate the arm.

WARNING

Failure to calibrate the robot after servicing will cause unexpected results that can lead to possible serious physical injury and/or damage to the robot, equipment, and other items located in the work cell.

Shoulder Joint

CAUTION

All replacement procedures should be performed with the controller turned off and unplugged. Proper precautions should be taken to protect electronics from damage caused by static discharge.

A. Removing the Shoulder Joint

1. Remove the large torso cover by removing the four screws with a 2.5 mm Allen wrench.
2. Remove the upper arm cover by removing the two screws with a 2.5 mm Allen wrench.
3. Disconnect the torso-shoulder cable from P1 on the torso PCB assembly.
4. Release tension on the elbow belt and the wrist (upper arm) belt by disengaging them from the swing arms.
 - a. Rotate the wrist belt swing arm (top, outer swing arm) clockwise until the belt no longer touches the swing arm pulley; slowly release the swing arm so that the wrist belt is free of the pulley.
 - b. Rotate the elbow belt swing arm (bottom, inner swing arm) clockwise until the belt no longer touches the swing arm pulley; slowly release the swing arm so that the elbow belt is free of the pulley.
5. Disconnect the wrist motor power and encoder cables from P6 and P7, respectively, on the elbow/wrist PCB assembly.
6. Disconnect the elbow motor power and encoder cables from P5 and P3, respectively, on the elbow/wrist PCB assembly.
7. Disconnect the torso-shoulder cable from P1 and the shoulder-forearm cable from P2 on the elbow/wrist PCB assembly.
8. Using a 3 mm Allen wrench, remove the three elbow/wrist bracket mounting screws and lift out the motor mount bracket assembly.
9. Remove the wrist (upper arm) and elbow belts.
10. Using a 2.5 mm Allen wrench, slightly loosen the three screws that hold the shoulder motor mounting bracket to the torso to release tension on the shoulder belt.
11. Remove the shoulder belt.
12. On the upper arm side of the joint, use 2.5 mm Allen wrench to remove the six screws that connect the upper arm casting to the shoulder joint and remove the upper arm, forearm and hand assemblies.

CAUTION

Hold the upper arm in place as you remove the retaining screws. Do not allow the dowel pins to bear the full weight of the assembly! Take care to pull the upper arm straight out so as not to damage the dowel pin hole and slot or the joint.

13. On the torso side of the joint, use a 2.5 mm Allen wrench to remove the six screws that connect the torso casting to the shoulder joint and remove the joint from the upper arm side.

CAUTION

Hold the joint in place as you remove the retaining screws. Do not allow the dowel pins to bear the full weight of the joint assembly! Take care to pull the shoulder joint straight out so as not to damage the dowel pin hole and slot or the joint.

B. Replacing the Shoulder Joint

1. Insert the new joint into the torso casting from the upper arm side of the joint by lining up the dowel pins in the shoulder joint with the corresponding mating hole and slot in the torso casting. Secure the joint with the six retaining screws that attach the joint to the torso casting using an adjustable torque screwdriver set for 10 in-lb. Use LocTite 242 on the screws.

CAUTION

Do not force the pins in the hole and slot! Be sure to use the correct screws! Screws longer than 6 mm can cause severe damage to the joint!

CAUTION

Hold the joint in place as you replace the retaining screws. Do not allow the dowel pins to bear the full weight of the assembly! Take care to hold the shoulder joint straight so as not to damage the dowel pin hole and slot or the joint.

2. Thread the end of the new cable without the connector through the shoulder joint from the torso side of the joint.
3. Feed the cables between the two motor/encoder assemblies.
4. Insert the four wires into the supplied connector in the order shown in figure 3-10.
5. Slip the upper arm over the joint by lining up the dowel pins in the shoulder joint with the corresponding mating hole and slot in the upper arm casting. Secure it with the six retaining screws that attach the upper arm casting to the joint using an adjustable torque screwdriver set for 10 in-lb. Use LocTite 242 on the screws.

CAUTION

Do not force the pins in the hole and slot! Be sure to use the correct screws! Screws longer than 10 mm can cause severe damage to the joint!

CAUTION

Hold the upper arm in place as you replace the retaining screws. Do not allow the dowel pins to bear the full weight of the assembly! Take care to hold the upper arm straight so as not to damage the dowel pin hole and slot or the joint.

6. Replace the shoulder belt and tighten the shoulder motor-mounting bracket (see “Replacing the Shoulder Belt,” steps B1–B3).
7. Replace the elbow/wrist motor/PCB bracket assembly (see “Replacing the Elbow/Wrist Motor/Encoder Assembly(s),” steps C5–C9).
8. Connect the torso-shoulder cable to P1 and the shoulder-forearm cable to P2 on the elbow/wrist PCB assembly.

9. Connect the elbow motor power and encoder cables from P5 and P3, respectively, on the elbow/wrist PCB assembly.
10. Connect the wrist motor power and encoder cables to P6 and P7, respectively, on the elbow/wrist PCB assembly.
11. Connect the torso-shoulder cable to P1 on the torso PCB assembly.
12. Replace the left torso cover and the upper arm cover.
13. Calibrate the arm.

WARNING

Failure to calibrate the robot after servicing will cause unexpected results that can lead to possible serious physical injury and/or damage to the robot, equipment, and other items located in the work cell.

Torso-Shoulder Cable

CAUTION

All replacement procedures should be performed with the controller turned off and unplugged. Proper precautions should be taken to protect electronics from damage caused by static discharge.

CAUTION

Carefully observe the routing of the cable prior to performing this procedure. It is critical that it be routed in exactly the same manner. Care must be taken to prevent the cable from coming in contact with any moving parts (e.g., belts).

A. Removing the Torso-Shoulder Cable

1. Remove both the left and right torso covers, using a 2.5 mm Allen wrench, by removing the four screws on each cover.
2. Remove the upper arm cover by removing the two screws with a 2.5 mm Allen wrench.
3. Disconnect the torso-shoulder cable from P1 on the torso PCB assembly.
4. Cut the cable tie that secures the torso-shoulder cable to the cable guide.
5. Disconnect the torso-shoulder cable from P1 on the elbow/wrist PCB and cut off the connector.
6. Pull the cable through the shoulder joint from the torso side of the joint.

B. Replacing the Torso-Shoulder Cable

1. Thread the end of the new cable without the connector through the shoulder joint from the torso side of the joint.
2. Feed the cable between the two motor/encoder assemblies.
3. Insert the four wires into the supplied connector in the order shown in figure 3-10.
4. Reconnect the torso-shoulder cable to P1 on the elbow/wrist PCB and P1 on the torso PCB assembly.
5. Secure the torso-shoulder cable to the cable guide with a new cable tie.
6. Replace both the left and right torso covers and upper arm cover.

Chassis/Torso Cable

CAUTION

All replacement procedures should be performed with the controller turned off and unplugged. Proper precautions should be taken to protect electronics from damage caused by static discharge.

CAUTION

Carefully observe the routing of the cable prior to performing this procedure. It is critical that it be routed in exactly the same manner. Care must be taken to prevent the cable from coming in contact with any moving parts (e.g., belts).

A. Removing the Chassis/Torso Cable

1. Remove the left and right torso covers, using a 2.5 mm Allen wrench, by removing the four screws on each cover.
2. Disconnect the shoulder motor power and encoder cables from P5 and P3, respectively, on the torso PCB assembly.
3. Disconnect the torso-shoulder cable from P1 on the torso PCB assembly.
4. Disconnect the chassis-torso ribbon cable from P4 on the torso PCB assembly.
5. Remove the torso PCB assembly by removing the three torso bracket-mounting screws using a no. 2 Pozidriv screwdriver; slide the board and bracket out of the torso.
6. Remove the plate on the left-hand end cap using a 2.5 mm Allen wrench.
7. Remove the rail cover using a no. 2 Pozidriv screwdriver. Remove the four screws on either side of each cap, move the robot to the far right of the rail, and slide the cover off.
8. Disconnect the torso from the chassis casting by removing the six screws at the base of the robot that connect the torso casting to the chassis.
9. Slowly lift the arm up, disconnect the chassis/torso cable from P2 on the chassis connector PCB assembly, and slide the chassis/torso cable out from under the rail cable clamp.
10. Lay the robot on its side and pry off the chassis/torso cable clamp that holds the chassis-torso cable in place.
11. Remove the chassis/torso cable and scrape any tape residue from the torso casting and chassis/torso cable clamp.

B. Replacing the Chassis/Torso Cable

1. Remove the shoulder motor/encoder assembly as outlined in “Removing the Shoulder Motor/Encoder Assembly,” steps A3–A6.
2. Lay the new chassis-torso ribbon cable in place. Orient the cable with the small 180-degree bend positioned at the bottom of the torso casting. This end will attach to the P2 connector on the chassis connector PCB assembly.
3. Feed the other end of the chassis/torso cable up through the slot in the torso casting that leads to the torso PCB assembly. This end will attach to the P4 connector on the torso PCB assembly.
4. Secure the chassis/torso cable by mounting the chassis /torso cable clamp such that it is centered in the unpainted area of the torso casting and is 1.5 mm from the bottom of the torso casting (use a new portion of double-sided adhesive tape).

NOTE! Make sure the chassis/torso cable can move freely beneath the chassis/torso cable clamp.

5. Slide the torso PCB/bracket assembly into the slot in the torso casting. Apply Loctite 242 to the torso bracket-mounting screws and replace the torso PCB assembly..
6. Replace the shoulder motor/encoder assembly as outlined in “Replacing the Shoulder Motor/Encoder Assembly,” page 3,32, steps B1–B6.
7. Reconnect the torso-shoulder cable and the chassis/torso cable to the appropriate connectors (see steps A3 and A4).
8. While supporting the arm, slide the chassis/torso cable under the rail cable clamp and reconnect to P2 on the chassis connector PCB assembly. Make sure the chassis/torso cable is tucked under the rail cable clamp.
9. Attach the robot to the chassis by replacing the six screws at the base of the robot
10. Replace the rail cover and end cap plate.
11. Replace both the left and right torso covers.
12. Calibrate the arm.

WARNING

Failure to calibrate the robot after servicing will cause unexpected results that can lead to possible serious physical injury and/or damage to the robot, equipment, and other items located in the work cell.

Chassis

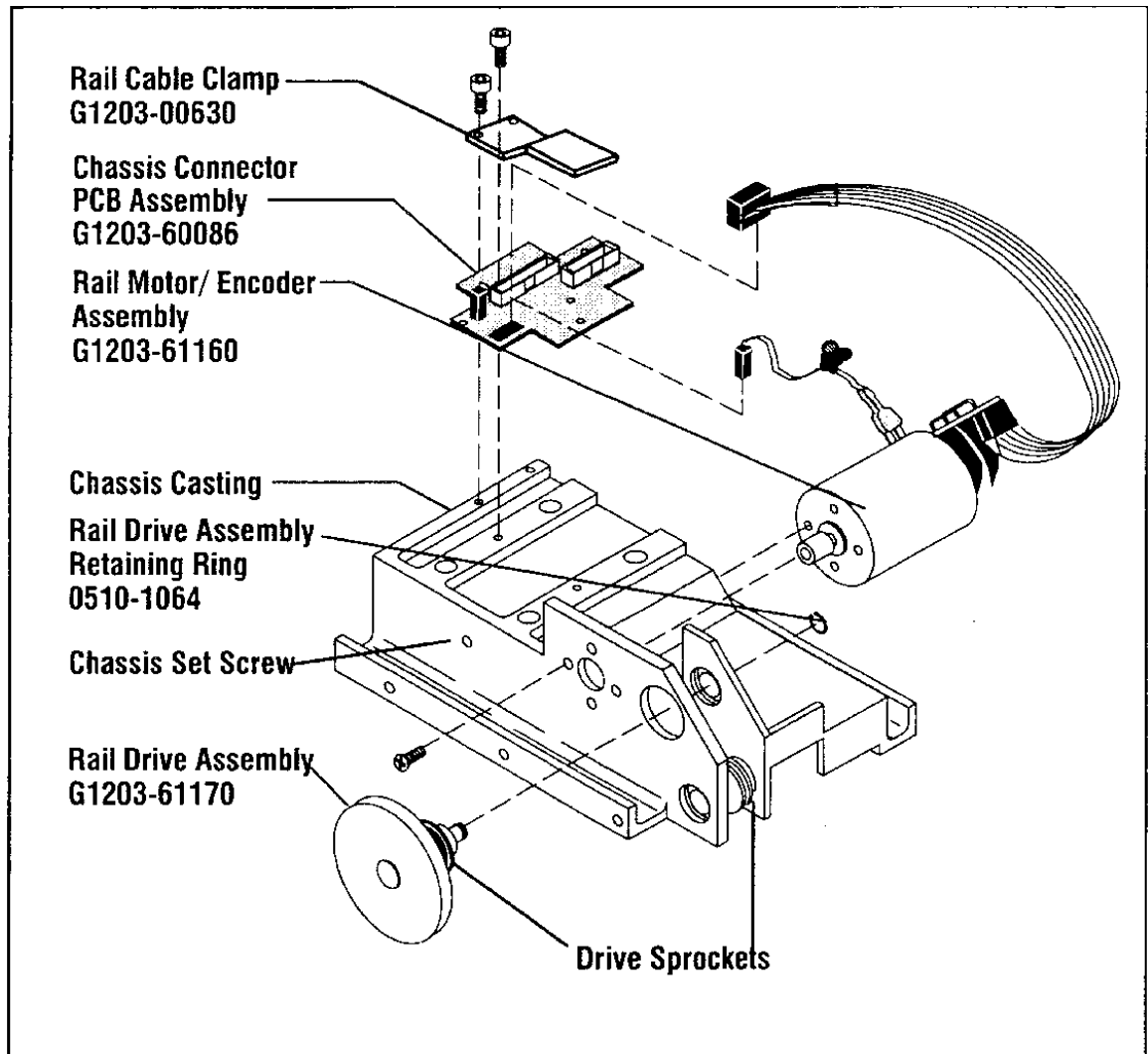

Figure 3-12. Chassis assembly.

Rail Motor/Encoder Assembly

CAUTION

All replacement procedures should be performed with the controller turned off and unplugged. Proper precautions should be taken to protect electronics from damage caused by static discharge.

A. Removing the Rail Motor/Encoder Assembly

1. Using a 2.5 mm Allen wrench, remove the plate on the left end cap.
2. Using a no. 2 Pozidriv screwdriver, take off the rail cover by removing the four screws on either side of each end cap. Move the arm to the far right end of the rail and slide the cover off.

3. Disconnect the torso from the chassis by removing the six shoulder screws at the base of the robot.
4. Slowly lift the arm up, disconnect the chassis/torso cable from P2 on the chassis connector PCB assembly, and slide the chassis/torso cable out from under the rail cable clamp.
5. Disconnect the rail chain at the right end cap and disengage the chain from the drive sprockets on the chassis.
6. Disconnect the rail motor power and encoder cables from J2 and J1, respectively, on the chassis connector PCB assembly.
7. Disconnect the grounding capacitor on the rail motor power cable from U1 on the chassis connector PCB assembly.
8. Remove the rail drive assembly retaining ring on the rail drive assembly.
9. Remove the rail drive assembly(a drive sprocket will come with it).
10. Note the orientation of the motor/encoder assembly; it will be required to position the new motor/encoder assembly in this same orientation.
11. Using a no. 2 Pozidriv screwdriver, unscrew the four rail motor-mounting screws and remove the motor.

B. Replacing the Rail Motor/Encoder Assembly

1. Apply LocTite 242 to the four rail mounting screws, and install the new motor by replacing the four motor-mounting screws. The orientation of the motor must match the orientation noted in step A10, above i.e., the encoder PCB on the rail motor/encoder assembly is positioned at about 10 o'clock).
2. Replace the rail drive assembly (with the drive sprocket).
3. Replace the rail drive assembly retaining ring on the back of the rail drive assembly.
4. Connect the rail motor power cable to J2 on the chassis connector PCB assembly.
5. Connect the grounding capacitor on the rail motor power cable to U1 on the chassis connector PCB assembly.
6. Connect the rail motor encoder cable to J1 on the chassis connector PCB assembly.
7. Thread the rail chain around the drive sprockets.
8. Engage the rail chain in the teeth of the right chain tensioner and screw the tensioner into the right end cap.
9. Tension the rail chain.
 - a. Move the chassis assembly to the extreme left end of the rail.
 - b. Place the rail chain tensioner gauge (Part no. G1203-61620) at the center of the rail chain.
 - c. Slip the rail chain into the slot on the rail chain tension gauge.
 - d. Push the tensioner piston all the way down then release it (this will load the rail chain tensioner gauge).

- e. Obtain a reading by depressing the reset button on the rail chain tensioner gauge.
- f. Repeat steps d and e until a consistent reading is obtained.
- g. Proper tensions for each rail length is shown in the table below.

Rail Length	Tension(+/- 0.025 lb.)
1 m	1.4
2 m	.7
3 m	.5

- h. To adjust the tension, tighten or loosen the right rail chain tensioner.
 - i. Repeat steps d and e until a consistent reading is obtained.
 - j. Place a small amount of locking compound (Part number 0470-0501) in the gap between the rail tensioner and the screw head.
10. While supporting the arm, slide the chassis/torso cable under the rail cable clamp and reconnect to P2 on the chassis connector PCB assembly. Make sure the chassis/torso cable is tucked under the rail cable clamp.
 11. Reconnect the arm by attaching the torso to the chassis using the six mounting screws.
 12. Replace the rail cover and end cap plate.
 13. Calibrate the arm.

WARNING

Failure to calibrate the robot after servicing will cause unexpected results that can lead to possible serious physical injury and/or damage to the robot, equipment, and other items located in the work cell.

Chassis Controller PCB Assembly

CAUTION

All replacement procedures should be performed with the controller turned off and unplugged. Proper precautions should be taken to protect electronics from damage caused by static discharge.

A. Removing the Chassis Controller PCB Assembly

1. Using a 2.5 mm Allen wrench, remove the plate on the left end cap.
2. Using a no. 2 Pozidriv screwdriver, take off the rail cover by removing the four screws on either side of each end cap, move the arm to the far right of the rail, and slide the cover off.
3. Disconnect the torso from the chassis by removing the six shoulder screws at the base of the robot.
4. Slowly lift the arm up, disconnect the chassis/torso cable from P2 on the chassis connector PCB assembly, and slide the chassis/torso cable out from under the rail cable clamp.
5. Remove the rail cable clamp.
6. Disconnect the rail cable from P1 on the chassis connector PCB assembly.
7. Disconnect the rail motor power cable from J2 on the chassis connector PCB assembly.
8. Disconnect the rail motor encoder cable from J1 on the chassis connector PCB assembly.
9. Using a 2.5 mm Allen wrench, unscrew the two chassis PCB assembly-mounting screws and remove the board.

B. Replacing the Chassis Connector PCB Assembly

1. Apply Loctite 242 to the mounting screws and replace the chassis connector PCB assembly.
2. Connect both motor cables to the new chassis PCB assembly. See steps A7–A8 above.
3. Reattach the metal rail cable support to the rail cable clamp.
4. Apply Loctite 242 to the screws that replace the rail cable clamp.
5. Reconnect the rail cable to P1 in the chassis connector PCB assembly.
6. While supporting the arm, slide the chassis/torso cable under the rail cable clamp and reconnect to P2 on the chassis connector PCB assembly. Make sure the chassis/torso cable is tucked under the rail cable clamp.
7. Reconnect the arm by attaching the torso to the chassis using the six mounting screws.
8. Replace the rail cover and the end cap plate.
9. Calibrate the arm.

WARNING

Failure to calibrate the robot after servicing will cause unexpected results that can lead to possible serious physical injury and/or damage to the robot, equipment, and other items located in the work cell.

Rail

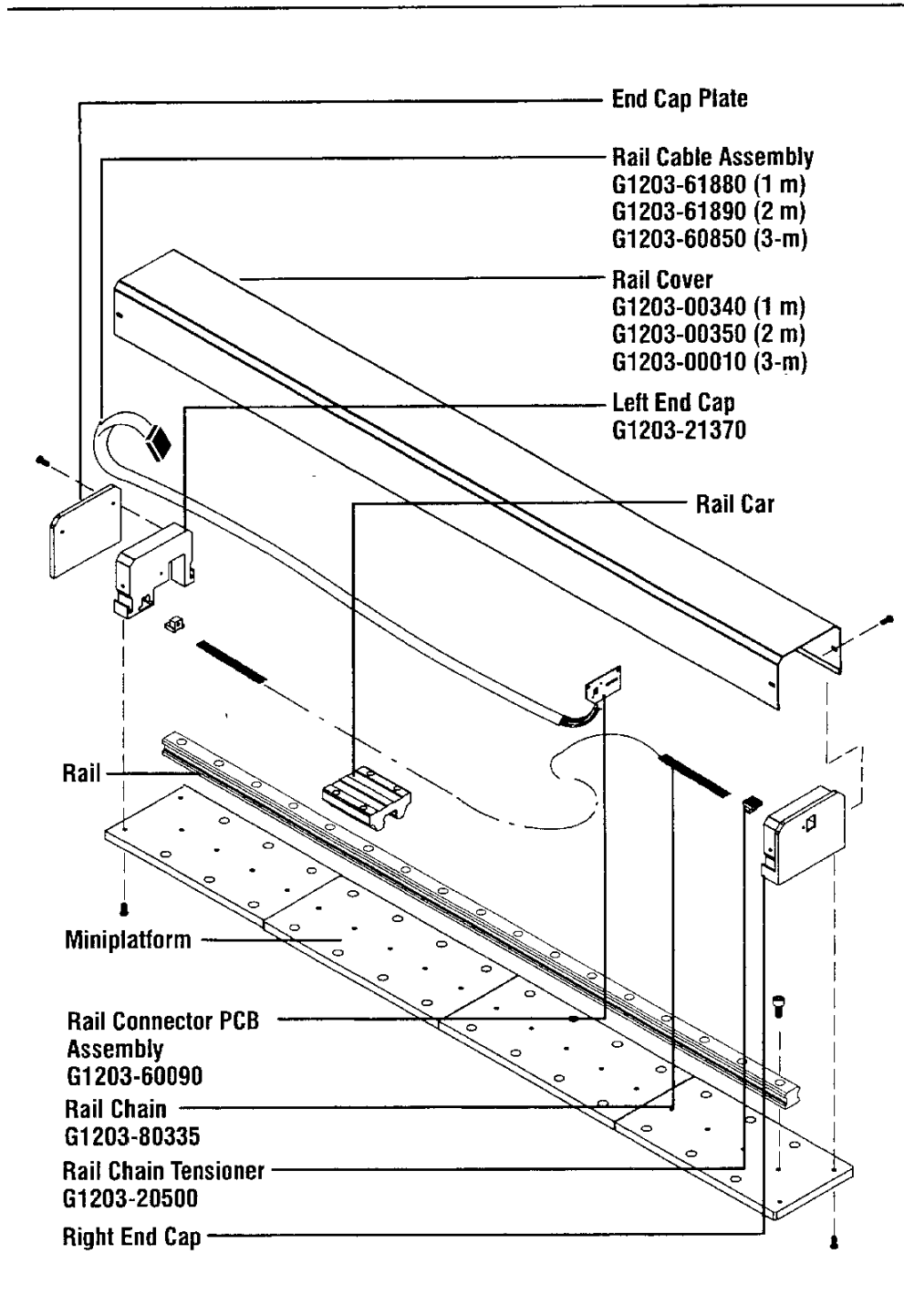

Figure 3-13. Rail assembly.

Rail Chain

CAUTION

All replacement procedures should be performed with the controller turned off and unplugged. Proper precautions should be taken to protect electronics from damage caused by static discharge.

A. Removing the Rail Chain

1. Using a 2.5 mm Allen wrench, remove the plate on the left end cap.
2. Using a no. 2 Pozidriv screwdriver, take off the rail cover by removing the four screws on either side of each end cap, move the arm to the far right end of the rail and slide the cover off.
3. Disconnect the torso from the chassis by removing the six shoulder screws at the base of the robot.
4. Slowly lift the arm up, disconnect the chassis/torso cable from P2 on the chassis connector PCB assembly, and slide the chassis/torso cable out from under the rail cable clamp.
5. Remove the right rail tensioner and disengage the rail chain.
6. Thread the rail chain through the two drive sprockets and out from under the chassis.
7. Remove the left rail tensioner and disengage the rail chain.

B. Replacing the Rail Chain

1. Cut a piece of rail chain approximately 1.2 m long (for a 1 m rail assembly) or 2.35 m long (for a 2 m rail assembly), or 3.5m long (for a 3 m assembly). Use the old chain as a reference guide.
2. Engage the new rail chain in the teeth of the left chain tensioner and screw the tensioner into the left end cap.
3. Apply a small portion of Locking Compound (Part no. 0470-0501) in the gap between the rail chain tensioner screw head and rail chain tensioner.
4. Thread the rail chain around the drive sprockets.
5. Engage the new rail chain in the teeth of the right chain tensioner and screw the tensioner into the right-hand end cap.
6. Tension the rail chain; if necessary, snip off a portion of the rail until the chain can be tensioned properly.
 - a. Move the chassis assembly to the extreme left end of the rail.
 - b. Place the rail chain tensioner gauge (Part no. G1203-61620) at the center of the rail chain.
 - c. Slip the rail chain into the slot on the rail chain tension gauge.
 - d. Push the tensioner piston all the way down then release it (this will load the rail chain tensioner gauge).
 - e. Obtain a reading by depressing the reset button on the rail chain tensioner gauge.

- f. Repeat steps d and e until a consistent reading is obtained.
- g. Proper tensions for each rail length is shown in the table below.

Rail Length	Tension(+/- 0.025 lb.)
1 m	1.4
2 m	.7
3 m	.5

- h. To adjust the tension, tighten or loosen the right rail chain tensioner.
 - i. Repeat steps d and e until a consistent reading is obtained.
 - j. Place a small amount of locking compound (Part number 0470-0501) in the gap between the rail tensioner and the screw head.
7. While supporting the arm, slide the chassis/torso cable under the rail cable clamp and reconnect to P2 on the chassis connector PCB assembly. Make sure the chassis/torso cable is tucked under the rail cable clamp.
 8. Reconnect the arm by attaching the torso to the chassis using the six mounting screws.
 9. Replace the rail cover and end cap plate.
 10. Calibrate the arm.

WARNING
Failure to calibrate the robot after servicing will cause unexpected results that can lead to possible serious physical injury and/or damage to the robot, equipment, and other items located in the work cell.

Rail Cable

CAUTION

All replacement procedures should be performed with the controller turned off and unplugged. Proper precautions should be taken to protect electronics from damage caused by static discharge.

A. Removing the Rail Cable

1. Using a 2.5 mm Allen wrench, remove the plate on the left end cap plate.
2. Using a no. 2 Pozidriv screwdriver, take off the rail cover by removing the four screws on either side of each end cap, move the arm to the far right end of the rail, and slide the cover off.
3. Disconnect the torso from the chassis by removing the six shoulder screws at the base of the robot.
4. Slowly lift the arm up, disconnect the chassis/torso cable from P2 on the chassis connector PCB assembly, and slide the chassis/torso cable out from under the rail cable clamp.
5. Remove the right rail tensioner and disengage the rail chain.
6. Thread the rail chain through the two drive sprockets and out from under the chassis casting.
7. Disconnect the ORCA bus cable (coming from the controller) from the right end cap connector.
8. Remove the three screws that secure the rail connector PCB assembly to the right end cap and remove the rail connector PCB assembly.
9. Remove the rail cable clamp from the chassis casting.
10. Disconnect the rail cable from P1 on the chassis connector PCB assembly.
11. Disconnect the metal rail cable support from the chassis casting.
12. Using a 2 mm Allen wrench, loosen the set screw located on the side of the chassis casting.
13. Using a 6 mm Allen wrench, remove the four screws that secure the chassis to the rail car and lift off the chassis casting.
14. Loosen the right end cap by loosening the screws that hold it to the right mini-platform. It may be necessary to remove the rail assembly from the work surface to do this.
15. Remove the metal rail cable support from beneath the right end cap.
16. Disconnect the rail cable from the rail connector PCB assembly.
17. Remove the rail cable.
18. Remove any used double-sided adhesive tape that may be stuck to the mini-platforms.

B. Replacing the Rail Cable

1. At the end of the rail cable with the hole in the metal strip, tuck the frayed ends of the sheath into the sheath as if forming a hem.
2. At the same end, adjust the ribbon cable/or metal strip so that the cable sticks out more than the metal strip. The center of the hole should be 22 mm (7/8 in) from the nearest side of the cable connector. The end of the sheath should be about 35 to 40 mm (1 3/8 to 1 9/16 in.) from the nearest side of the connector.
3. Lay the cable assembly flat on the mini-platforms with the chassis end to your left and the metal strip down toward the mini-platform.
4. Place the chassis assembly on the rail car, making sure the rail cable is located properly under the chassis casting.
5. Using LocTite 242, replace the four mounting screws that attach the chassis casting to the rail car; do not tighten completely.
6. Apply LocTite 242 and tighten the set screw on the side of the chassis casting while gently pushing down on the chassis casting. Finish tightening the four large mounting screws that attach the chassis casting to the rail car.
7. Connect the metal rail cable support to the rail cable clamp. Connect the rail cable to P1 on the chassis connector PCB assembly. Reattach the chassis cable clamp to the chassis casting using LocTite 242 on the two screws.
8. At the right end of the rail cable, tuck the frayed ends of the sheath into the sheath as if to form a hem. This is the end that will attach to the right end cap.
9. Plug the right end of the ribbon cable into the rail connector PCB assembly.
10. Attach the rail connector PCB assembly to the right end cap using 3 screws with LocTite 242.
11. Move the chassis to the left bumper. Adjust the cable so that it does not protrude through the left end cap. Pass the metal strip under the right end cap. Cut off any excess metal strip so it will not stick out from under the end cap.
12. Using LocTite 242, tighten the screws that hold the right end cap to the right mini-platform. If necessary, reattach the rail assembly to the work surface.
13. Clean off a space on the center mini-platform piece with methanol. Attach the cable sheath at this point using double-sided adhesive tape.
14. Thread the rail chain around the drive sprockets.
15. Engage the new rail chain in the teeth of the right chain tensioner and screw the tensioner into the right end cap.
16. Tension the rail chain
 - a. Move the chassis assembly to the extreme left end of the rail.
 - b. Place the rail chain tensioner gauge (Part no. G1203-61620) at the center of the rail chain.
 - c. Slip the rail chain into the slot on the rail chain tension gauge.
 - d. Push the tensioner piston all the way down then release it (this will load the rail chain tensioner gauge).
 - e. Obtain a reading by depressing the reset button on the rail chain tensioner gauge.

- f. Repeat steps d and e until a consistent reading is obtained.
- g. Proper tensions for each rail length is shown in the table below.

Rail Length	Tension(+/- 0.025 lb.)
1 m	1.4
2 m	.7
3 m	.5

- h. To adjust the tension, tighten or loosen the right rail chain tensioner.
 - i. Repeat steps d and e until a consistent reading is obtained.
 - j. Place a small amount of locking compound (Part number 0470-0501) in the gap between the rail tensioner and the screw head.
17. While supporting the arm, slide the chassis/torso cable under the rail cable clamp and reconnect to P2 on the chassis connector PCB assembly. Make sure the chassis/torso cable is tucked under the rail cable clamp.
 18. Reconnect the arm by attaching the torso to the chassis using the six mounting screws.
 19. Reconnect the ORCA bus cable (coming from the controller) to the connector on the right end cap.
 20. Replace the rail cover and end cap plate.
 21. Calibrate the arm.

WARNING

Failure to calibrate the robot after servicing will cause unexpected results that can lead to possible serious physical injury and/or damage to the robot, equipment, and other items located in the work cell.

Rail Connector PCB Assembly

CAUTION

All replacement procedures should be performed with the controller turned off and unplugged. Proper precautions should be taken to protect electronics from damage caused by static discharge.

A. Removing the Rail Connector PCB Assembly

1. Using a 2.5 mm Allen wrench, remove the plate on the left end cap plate.
2. Using a no. 2 Pozidriv screwdriver, take off the rail cover by removing the four screws on either side of each end cap, move the arm to the far right of the rail, and slide the cover off.
3. Unplug the ORCA bus cable (coming from the controller) from the connector on the right end cap.
4. Using a 2.5 mm Allen wrench, unscrew the three screws that attach the rail connector PCB assembly to the right end cap and remove the rail connector PCB assembly.
5. Disconnect the rail cable from the rail connector PCB assembly.

B. Replacing the Rail Connector PCB Assembly

1. Connect the rail cable to the new rail connector PCB assembly.
2. Apply Loctite 242 to the screws and secure the new rail connector PCB assembly onto the right end cap.
3. Replace the rail cover and left end cap plate.
4. Connect the ORCA bus cable (coming from the controller) to the connector on the right end cap.

Controller

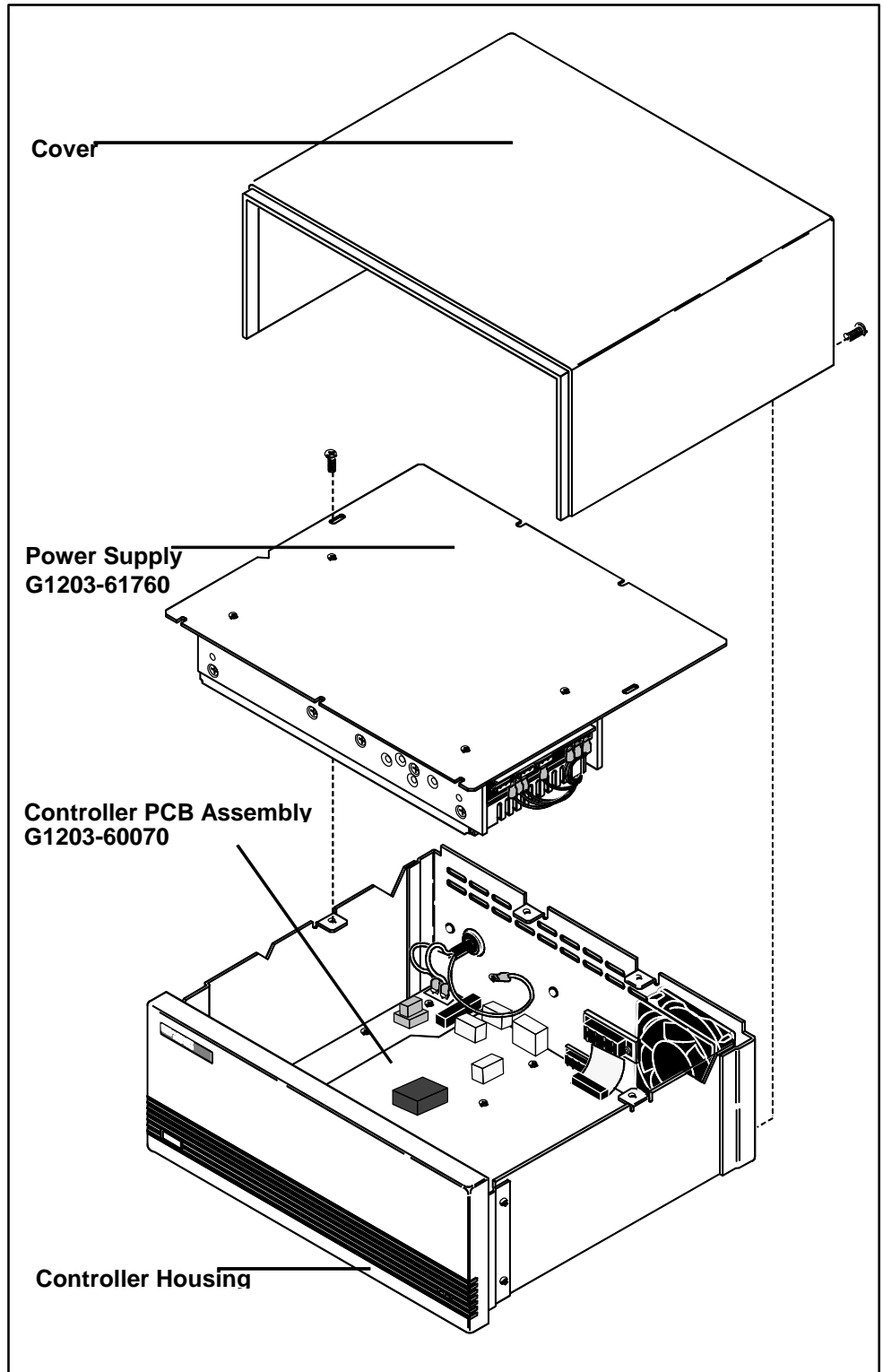

Figure 3-14. Robot controller PCB exploded diagram.

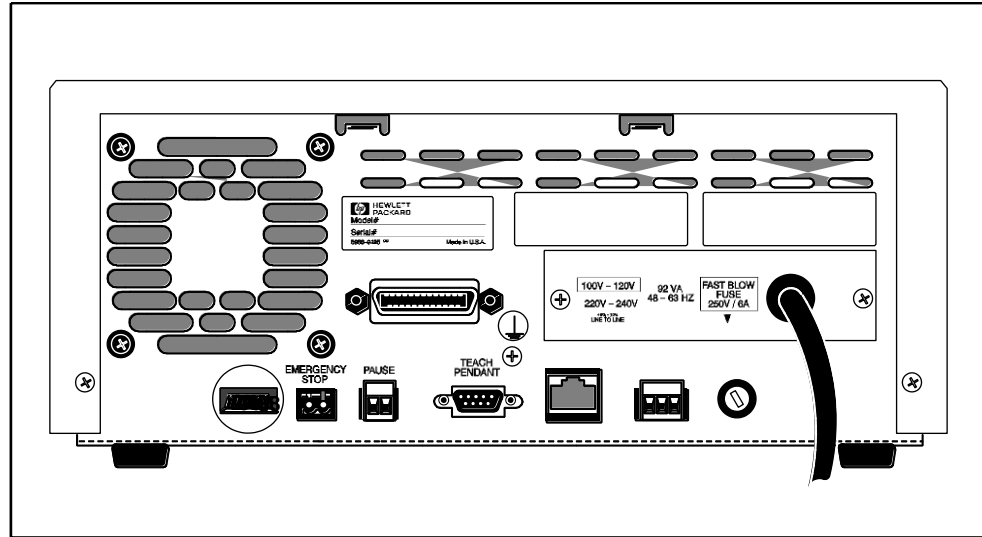

Figure 3-15. Controller rear panel.

Controller Power Supply

CAUTION

All replacement procedures should be performed with the controller turned off and unplugged. Proper precautions should be taken to protect electronics from damage caused by static discharge.

A. Removing the Controller Power Supply

1. Turn off and unplug the controller.
2. Using a no. 1 Pozidriv, remove the two small screws on the back of the controller and take off the plastic outside cover.
3. Using a no. 2 Pozidriv, remove the seven large screws on top of the controller.
4. Carefully lift up the top cover and power supply assembly.
5. Unplug the connectors from the power supply to pins J3 and P3 on the controller PCB and remove the power supply.

B. Replacing the Controller Power Supply

1. Attach the two connectors from the new power supply to pins J3 and P3 on the controller PCB assembly.
2. Place the power supply on the controller housing and secure with the seven retaining screws.
3. Replace the top cover.
4. Plug in the controller and turn it on.

Controller PCB

CAUTION

All replacement procedures should be performed with the controller turned off and unplugged. Proper precautions should be taken to protect electronics from damage caused by static discharge.

A. Removing the Controller PCB

1. Remove the controller power supply as outlined in “Removing the Controller Power Supply,” steps A1–A5.
2. Remove the green connectors on the back of the controller by pulling them straight out.
3. Using a nut driver or wrench, disconnect the HP-IB connector from the connector rear panel.
4. Disconnect the AC power cord from pins P7 and P2 on the controller PCB
5. Remove the front cover from the controller.
6. Using a no. 2 Pozidriv, remove the eleven retaining screws on the controller PCB assembly and slide the controller PCB assembly forward slightly to access the fan power connector on the controller PCB assembly.
7. Disconnect the fan power cable from P4 on the controller PCB assembly.
8. Remove the controller PCB assembly.
9. Remove the firmware EPROM from U7 socket from the old controller PCB assembly and insert it in the corresponding U7 socket in the new controller PCB assembly.
10. Remove the firmware EPROM from U9 socket from the old controller PCB assembly and insert it in the corresponding U9 socket in the new controller PCB assembly.
11. Remove the communications processor from the U27 socket on the old controller PCB assembly and place in the corresponding U27 socket on the new controller PCB assembly.
12. Carefully remove the white on/off button from the spring-loaded power switch.

B. Replacing the Controller PCB

1. Slide the new controller PCB assembly into the controller housing.
2. Reconnect the fan power cable to P4 on the controller PCB assembly.
3. Apply Loctite 242 to the eleven retaining screws and secure the controller PCB assembly to the controller housing.
4. Carefully attach the white on/off button to the spring-loaded power switch on the new controller PCB assembly.
5. Replace the controller front cover. Take care to position the red and green LEDs properly in the plastic sockets.

6. Reconnect the AC power cord connectors to their appropriate connectors on the controller PCB assembly (see step A4, above).
7. Using a nut driver or wrench, reconnect the HP-IB connector to the controller rear panel.
8. Reconnect the green connectors to the back of the controller box.
9. Replace the controller power supply as outlined in “Replacing the Controller Power Supply,” steps B1–B4.
10. Calibrate the arm.

WARNING

Failure to calibrate the robot after servicing will cause unexpected results that can lead to possible serious physical injury and/or damage to the robot, equipment, and other items located in the work cell.